

Air lever-type Clamping Cylinder

ALC series

最大使用壓力 Max: 10kg/cm²

訂購範例：Ordering Example

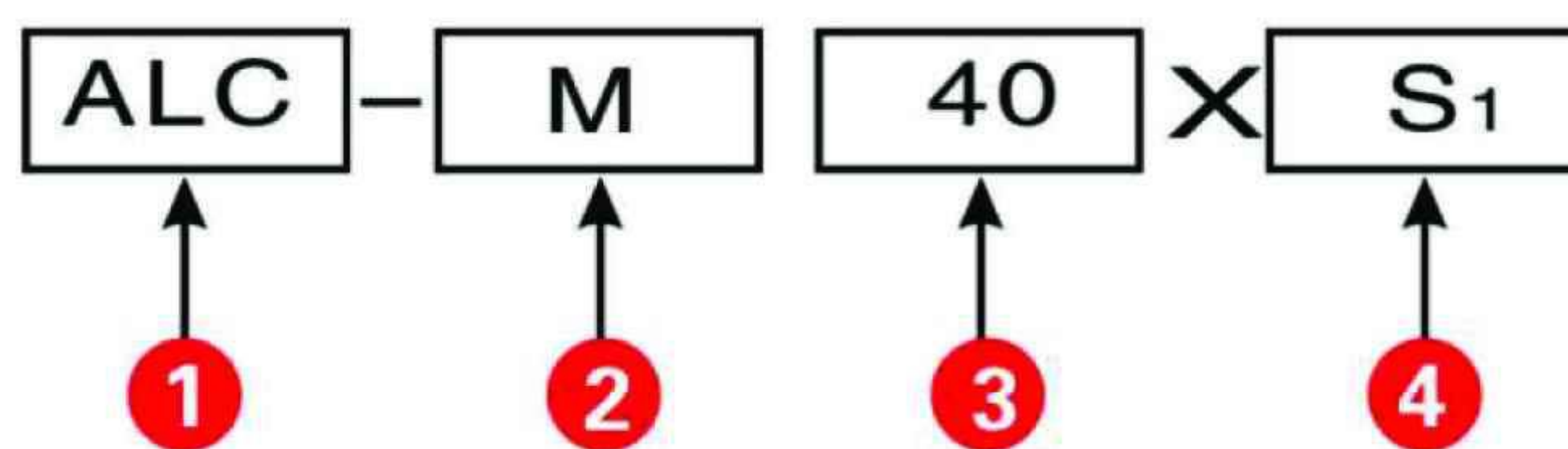
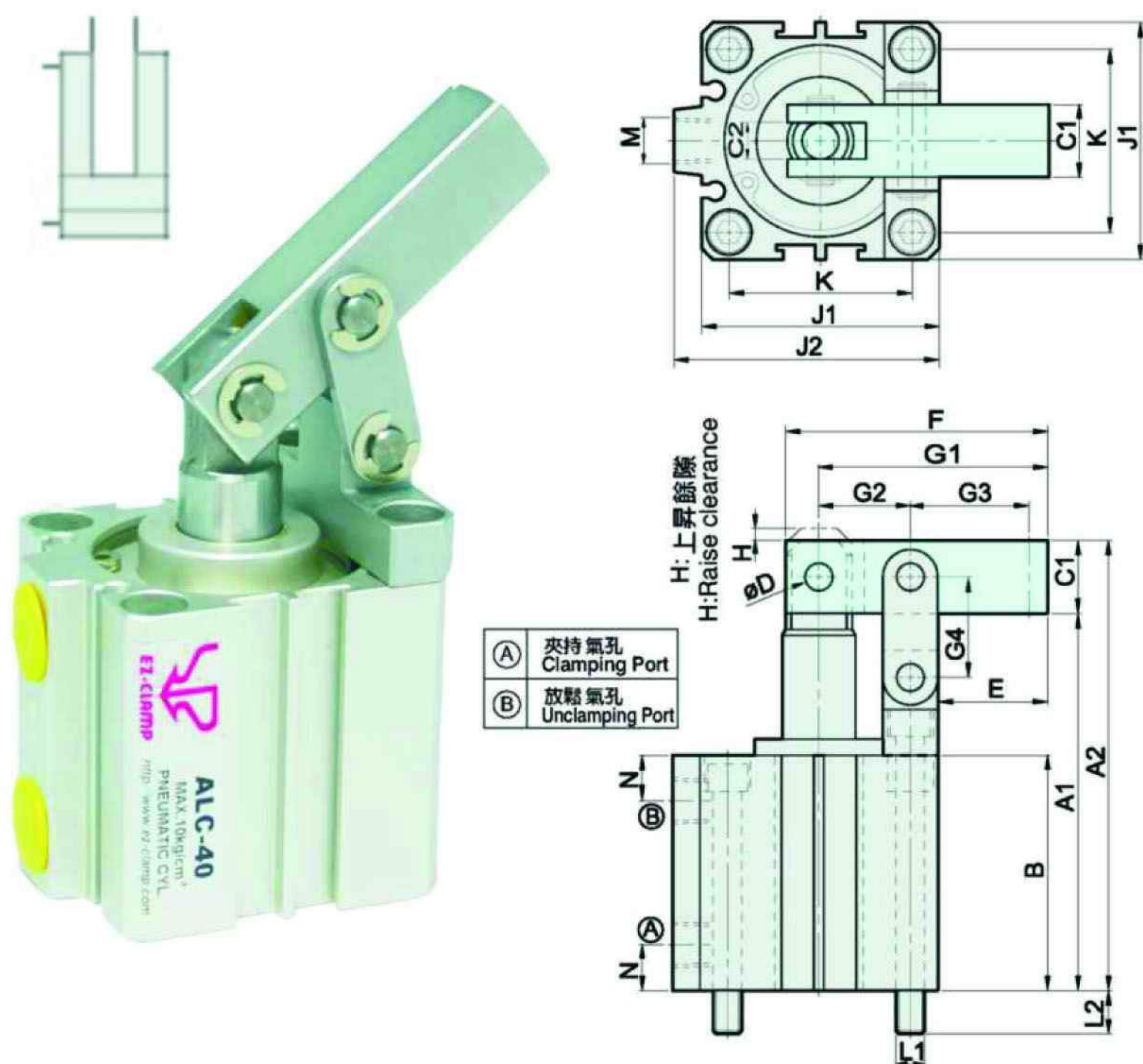

1	系列別	ALC
2	空白 Blank	標準型 Standard type
	M	附磁石感應 with magnetic ring
3	氣缸內徑 Bore dia	φ25 φ32 φ40 φ50 φ63
4	近接開關 Sensor	S1:1個 S2:2個

規格型號 TYPE		ALC-25	ALC-32	ALC-40	ALC-50	ALC-63
氣缸內徑 bore dia		φ25	φ32	φ40	φ50	φ63
活塞桿徑 piston rod dia		φ10	φ12	φ16	φ20	φ20
總行程 total stroke		20	23	25	30	35
受壓面積cm ² pressure area		4.91	8.04	12.57	19.63	31.17
理論夾持力 6kg/cm ²		15	25	44	71	136
使用流體 fluid		已濾清之壓縮空氣 filtered air				
最大操作壓力 max.pressure		10kg/cm ²				
使用壓力範圍 normal pressure		1-7kg/cm ²				
作動方式 acting type		複動 double acting				
標準型 standard	A1	65.5	78	82.5	96.6	115.5
	A2	78.2	93.9	98.4	115.6	137.7
	B	41	49	51.5	58.6	72.5
感應型 M with magnet	A1	75.5	93	97.5	106.6	125.5
	A2	88.2	108.9	113.4	125.6	147.7
	B	51	64	66.5	68.6	82.5
C1		□12.7	□15.9	□15.9	□19	□22.2
C2		6	8	8	10	10
D		φ5	φ6	φ6	φ8	φ8
E		25	31	32	35	38.5
F		50	60	65	75	85
G1		45	54	58	66	76
G2		14	17	20	23	29.5
G3		27.5	33	34	38	40.5
G4		17	20	22	27	32
H		3	3	3	3	3
J1		40	44	52	62	75
J2		-	50	58	71	84.5
K		28	34	40	48	60
L1		M5x0.8	M5x0.8	M6x1.0	M6x1.0	M6x1.0
L2		10.5	11	9.5	11	11
M		M5x0.8	PT1/8	PT1/8	PT1/4	PT1/4
N		8	9	10	11	11
Weight 重量(Kg)		0.27	0.42	0.55	0.95	1.45
with magnet M weight 重量(Kg)		0.29	0.48	0.63	1.05	1.6

網址: www.fdzc.net 联系人: 程家雄 手机: 13601809714

unit 單位: mm

联系电话: 021-51872743 E-mail: chengff@sh163.net