

# 薄型油压缸 Hydraulic Block Cylinder

## 外觀尺寸圖 Dimensions Tables

● HC-SD-□□□-□□□□-IN

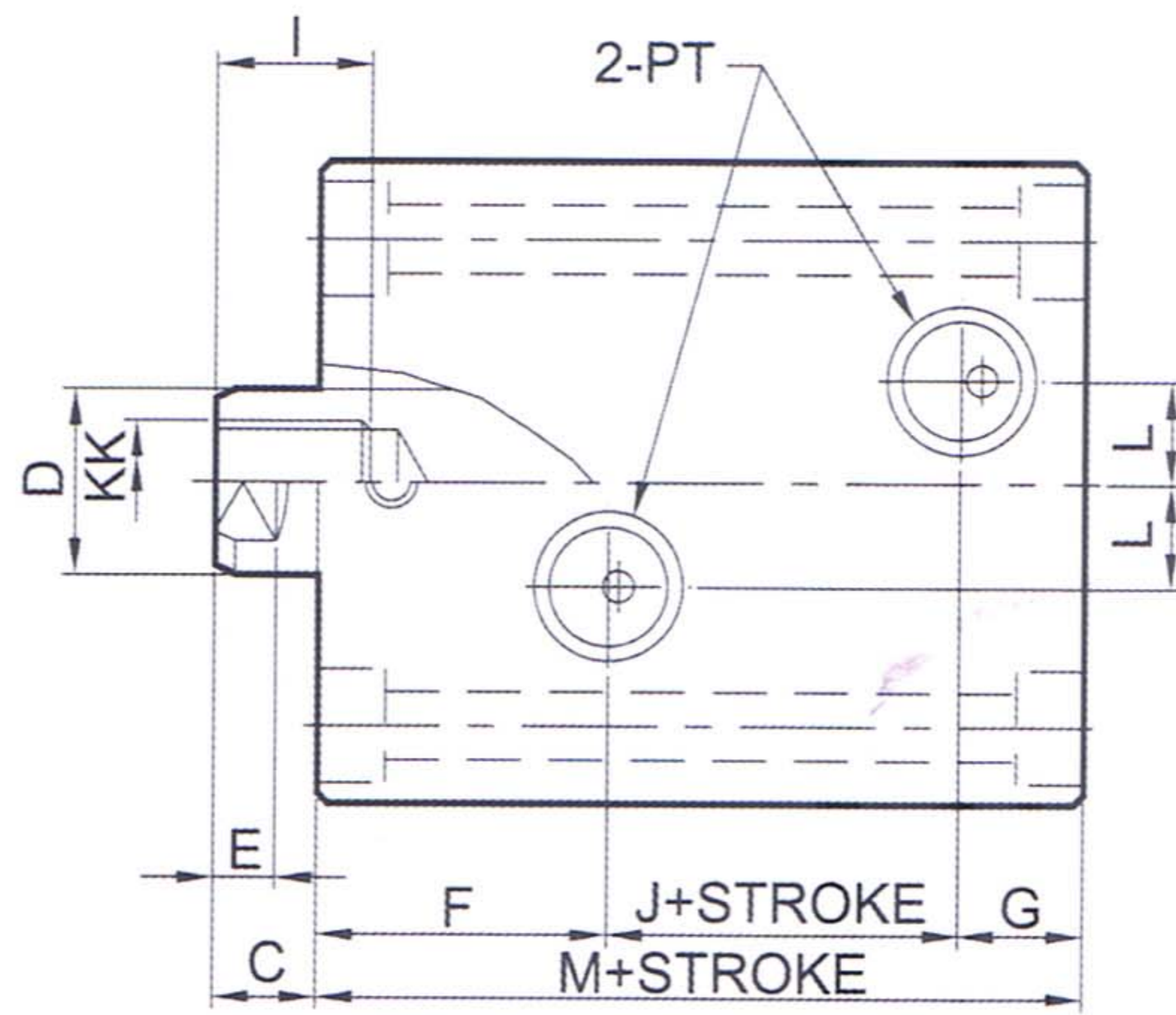
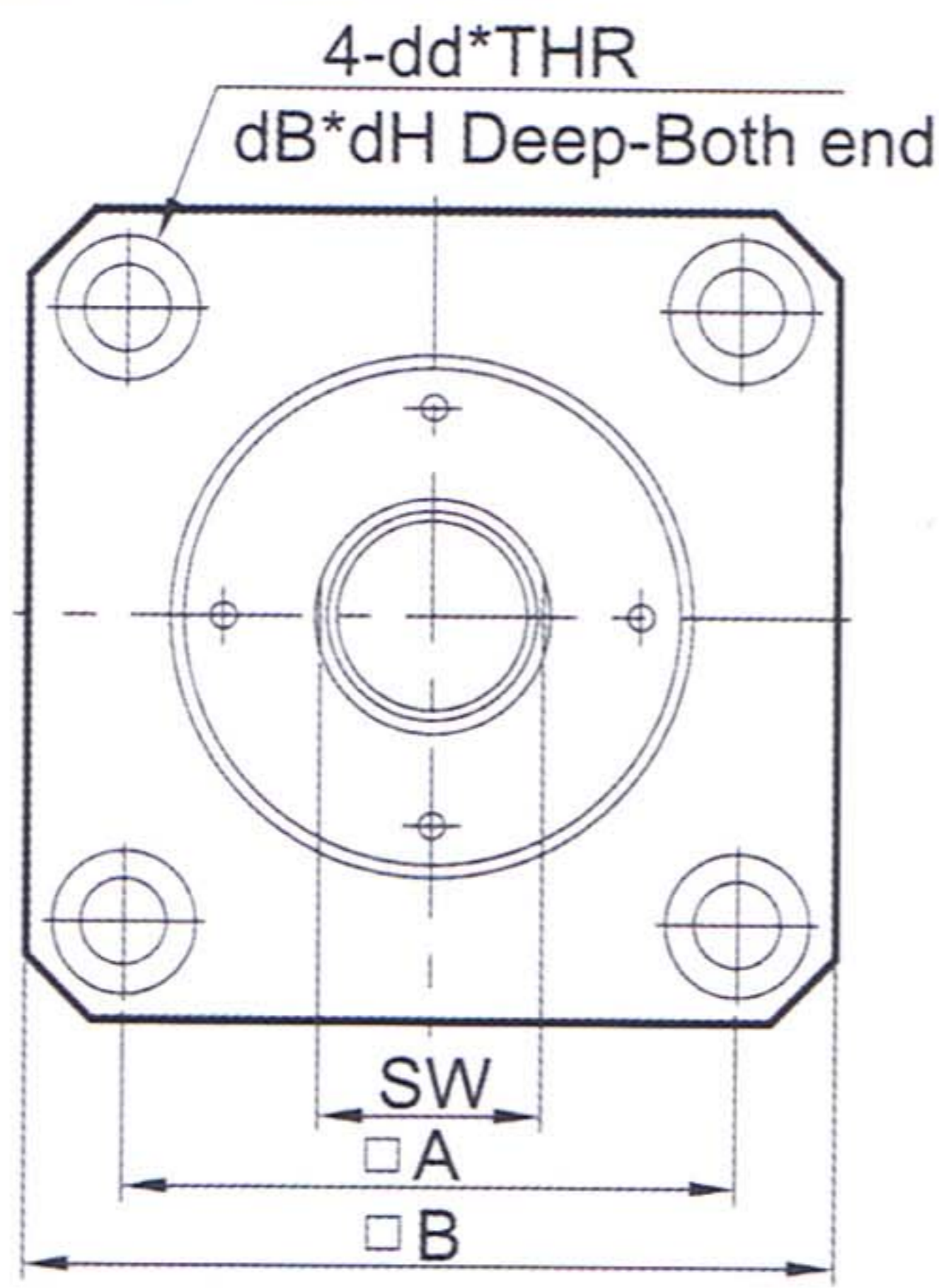

Unit:mm

	A	B	C	D	dB	dd	dH	E	F	G	I	J	KK	L	M	PT	SW
φ 20	30	42	8	φ 12	φ 9.5	φ 5.5	5.4	6	20.5	12	10	10.5	M8*P1.25	5	43	Rc 1/8"	10
φ 25	36	50	8	φ 14	φ 9.5	φ 5.5	5.4	6	20.5	12	12	12.5	M10*P1.5	7	45	Rc 1/8"	12
φ 32	47	62	10	φ 18	φ 11	φ 6.6	6.5	7	28	12	15	14	M12*P1.75	10	54	Rc 1/4"	16
φ 40	52	70	10	φ 22.4	φ 14	φ 9	8.6	7	28	12	20	15	M16*P2.0	10	55	Rc 1/4"	21
φ 50	58	80	11	φ 28	φ 17.5	φ 11	10.8	8	28	13	24	19	M20*P2.5	10	60	Rc 1/4"	25
φ 63	69	94	13	φ 35.5	φ 20	φ 14	13	9	30	13	33	24	M27*P3.0	10	67	Rc 1/4"	31
φ 80	86	114	17	φ 45	φ 23	φ 16	15.2	14	35	18	33	25	M30*P3.5	15	78	Rc 1/4"	41
φ 100	102	134	17	φ 56	φ 26	φ 18	17.5	14	39	18	40	36	M36*P4.0	15	93	Rc 3/8"	50

## 外觀尺寸圖 Dimensions Tables

● HC-SD-□□□-□□□□-EX

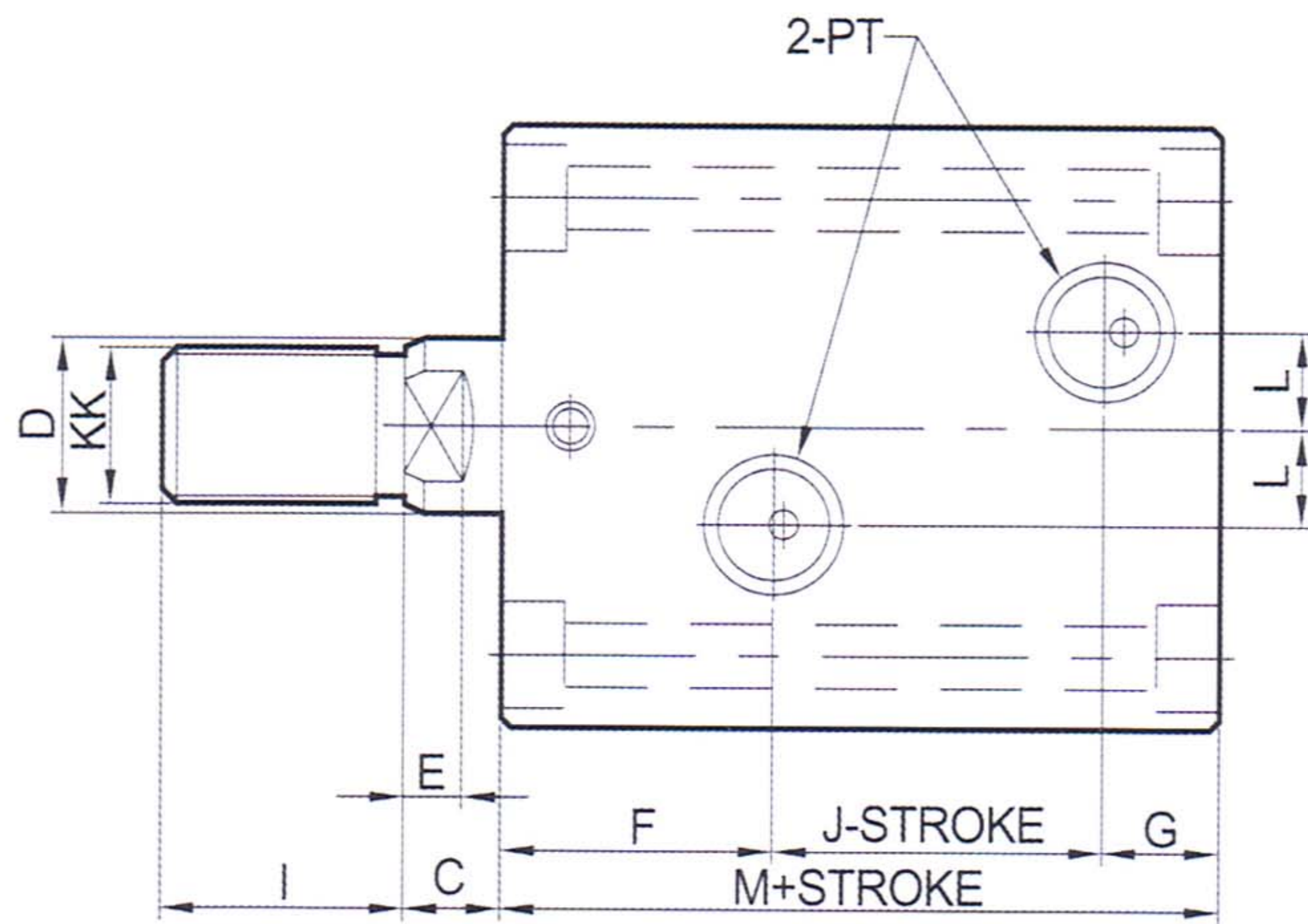
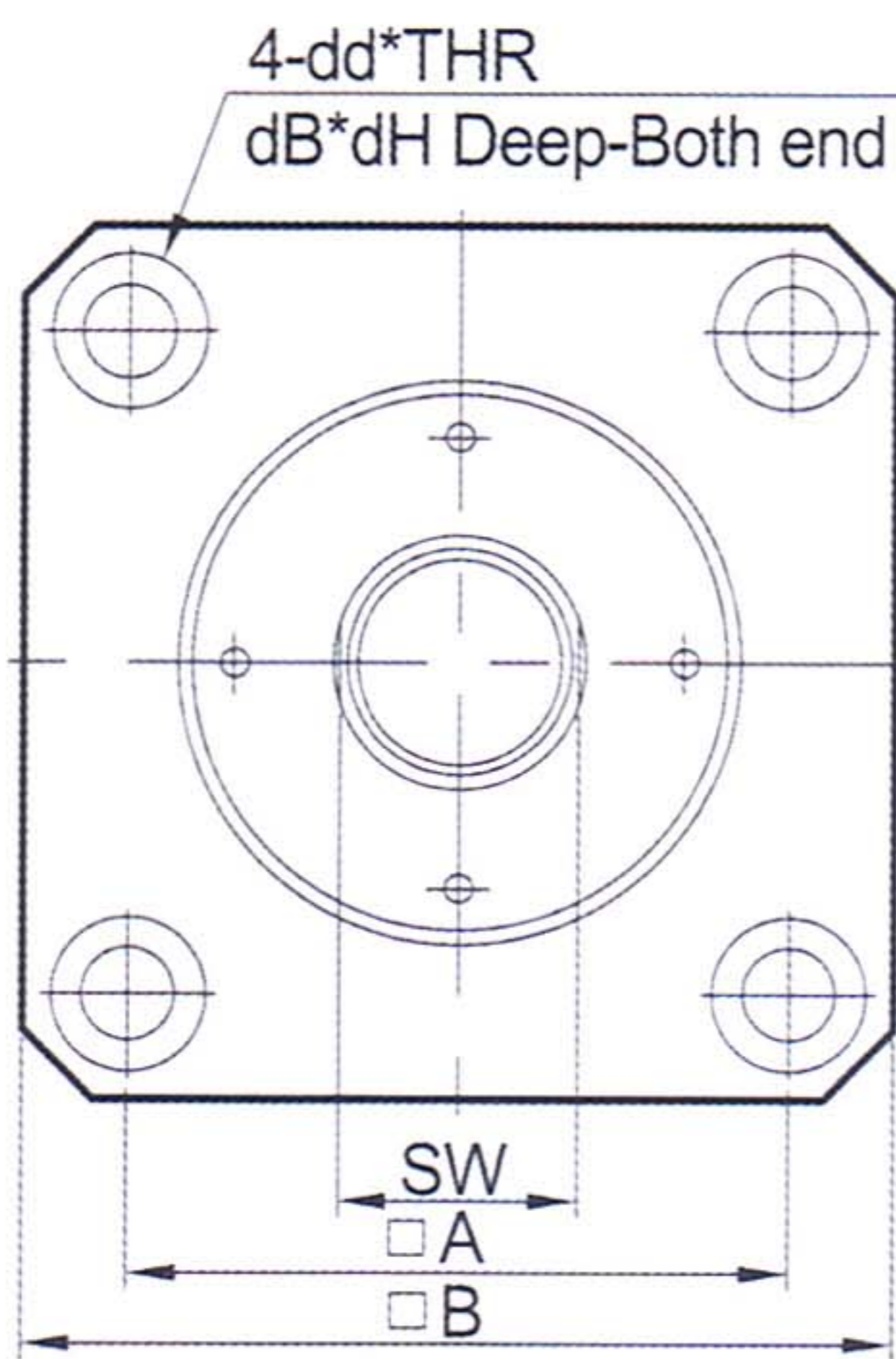

Unit:mm

	A	B	C	D	dB	dd	dH	E	F	G	I	J	KK	L	M	PT	SW
φ 20	30	42	8	φ 12	φ 9.5	φ 5.5	5.4	6	20.5	12	15	10.5	M10*P1.25	5	43	Rc 1/8"	10
φ 25	36	50	8	φ 14	φ 9.5	φ 5.5	5.4	6	20.5	12	18	12.5	M12*P1.25	7	45	Rc 1/8"	12
φ 32	47	62	10	φ 18	φ 11	φ 6.6	6.5	7	28	12	25	14	M16*P1.5	10	54	Rc 1/4"	16
φ 40	52	70	10	φ 22.4	φ 14	φ 9	8.6	7	28	12	30	15	M20*P1.5	10	55	Rc 1/4"	21
φ 50	58	80	11	φ 28	φ 17.5	φ 11	10.8	8	28	13	35	19	M24*P1.5	10	60	Rc 1/4"	25
φ 63	69	94	13	φ 35.5	φ 20	φ 14	13	9	30	13	45	24	M30*P1.5	10	67	Rc 1/4"	31
φ 80	86	114	17	φ 45	φ 23	φ 16	15.2	14	35	18	60	25	M39*P1.5	15	78	Rc 1/4"	41
φ 100	102	134	17	φ 56	φ 26	φ 18	17.5	14	39	18	75	36	M48*P1.5	15	93	Rc 3/8"	52

网址: [www.fdzc.net](http://www.fdzc.net) 联系人: 程家雄 手机: 13601809714

联系电话: 021-51872743

E-mail: [chengff@sh163.net](mailto:chengff@sh163.net)