

HLC series

Hydraulic lever-type Clamping Cylinder

最大使用壓力 Max:70kg/cm² Bore:ø25-ø63mm

管接式: Line Type

油路板式: Manifold Type

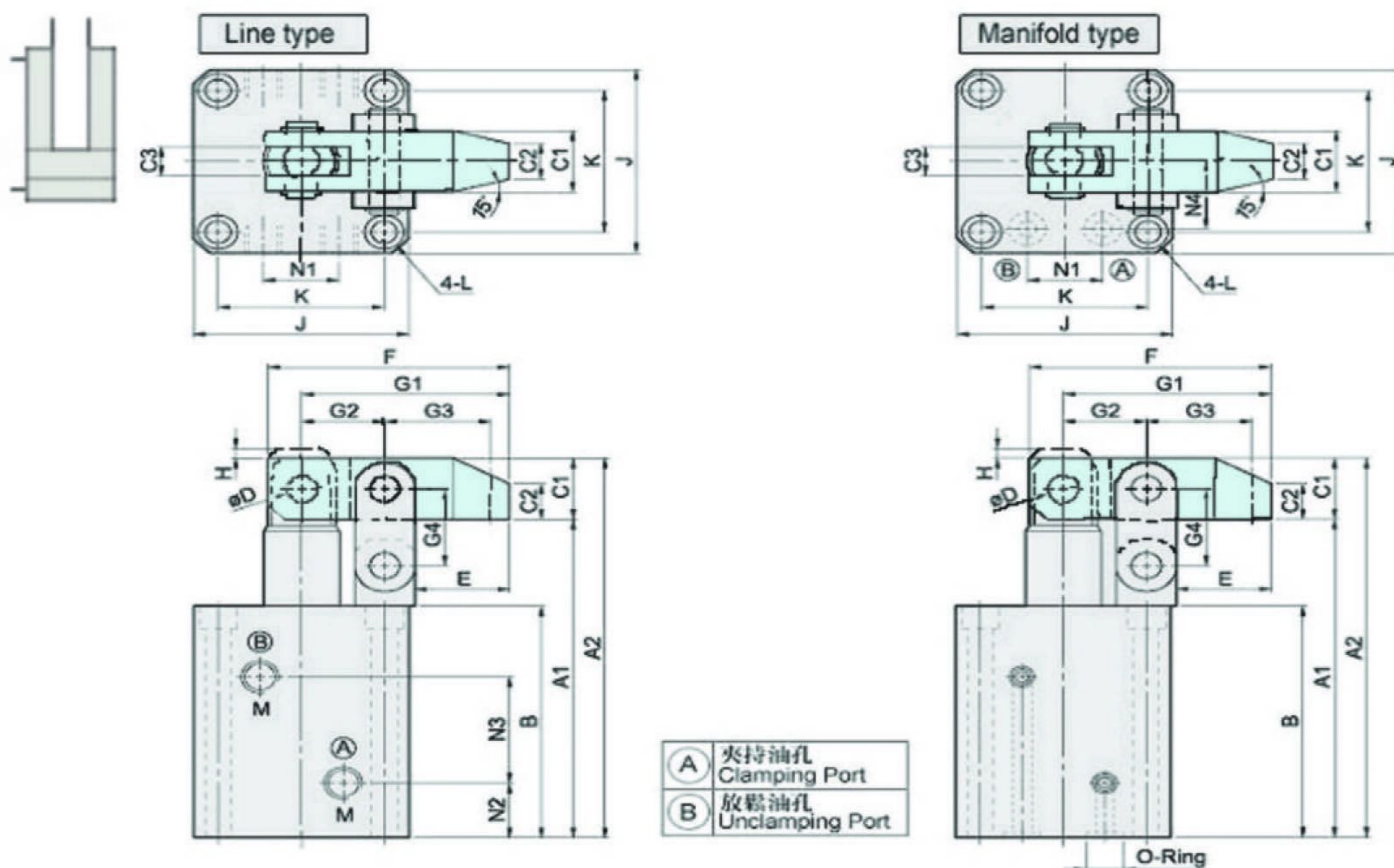

規格型號 Type	管接式 Line Type	HLC-25	HLC-32	HLC-40	HLC-50	HLC-63
	油路板型 O-ring Manifold	HLC-M25	HLC-M32	HLC-M40	HLC-M50	HLC-M63
油缸內徑 bore of cylinder		ø25	ø32	ø40	ø50	ø63
活塞杆徑 piston rod dia.		ø18	ø20	ø22.4	ø28	ø35
總行程 total stroke		25	25	30	34	40
受壓面積 拉入/推出 cm ²		2.37/4.91	4.9/8.04	8.63/12.57	13.47/19.63	21.56/31.17
理論夾力(30kg/cm ²) clamping force		116	190	288	453	701
使用流體 fluid		filtered hydraulic oil 已濾清之標準液壓油				
最大操作壓力 Max.pressure		70kg/cm ²				
使用壓力範圍 normal pressure		5-50kg/cm ²				
作動方式 acting type		複動式 double acting				
A1		103	112	122	137	155
A2		122	131	144.2	162.4	186.8
B		76	85	90	100	111
C1		□19	□19	□22.2	□25.4	□31.8
C2		11	11	13	15	19
C3		9	9	10	11	15
øD		ø8	ø8	ø10	ø12	ø15
E		25	25	30	35.5	43
F		64	64	77	90	110
G1		55	55	66	77	94
G2		22	22	26	30	36
G3		28	28	34	39	48
G4		24	24	29	33	39
H		3	3	4	4	4
J		55	57	69	75	96
K		42	44	52	58	75
L		ø6.8-ø10.5x6.5D	ø6.8-ø10.5x6.5D	ø9-ø14x9D	ø9-ø14x9D	ø11-ø18x11D
M		PT1/8	PT1/8	PT1/4	PT1/4	PT1/4
N1		18	22	26	32	38
N2		17	19	19	21.5	22
N3		33	38	40	45	52
N4		20	22	26	30	38
油封 o-ring		P7	P7	P8	P8	P9
weight 重量 kg		1.9	2.1	3.3	4.5	8.4

unit 單位: mm

網址: www.fdzc.net 联系人: 程家雄 手机: 13601809714

联系电话: 021-51872743 E-mail: chengff@sh163.net