

Hydro-Cylinder with Locking Piston

single acting with spring return,
max. operating pressure 500 bar

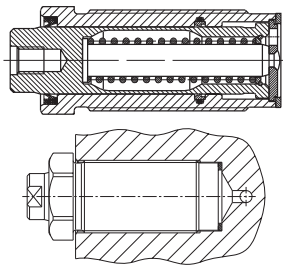

Threaded-body cylinder
with locking piston (page 2)



Block cylinder
with locking piston (page 3)

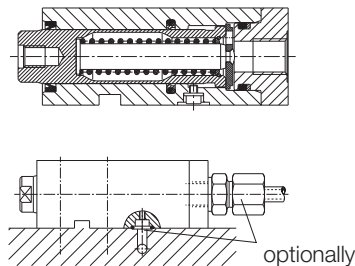

Low-block clamping cylinder
with locking piston (page 4)

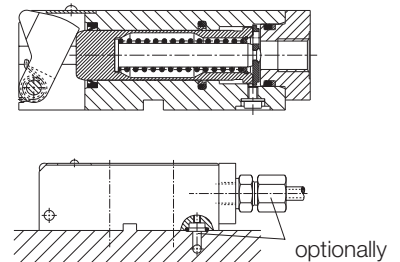

Description

Hydro cylinders with locking piston are single-acting plunger cylinders, similar to the design of the proved threaded-body cylinders as per data sheet B 1.461. When pressurising the element, the piston will be expanded and locked in the cylinder body.

Function

If a force F_B higher than the hydraulic clamping force F_{Hyd} , acts on a standard clamping cylinder, the piston will be pushed back due to the compressibility of the oil.

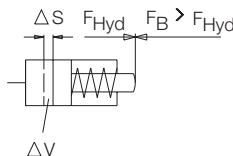

In such cases the operating pressure has to be increased or a larger clamping cylinder or additional work supports have to be used. The hydro cylinder with locking piston does not only clamp the workpiece, but compensates also the machining forces which are up to five times higher and are directed against the clamping force.

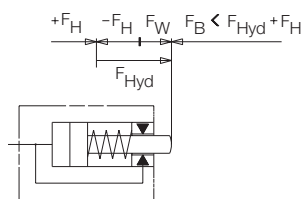

- F_{Hyd} = Hydraulic clamping force
= Piston surface x oil pressure
- F_W = Effective clamping force
 $F_{Hyd} - F_H$
- F_H = Retention force, resulting from non-positive locking of the piston in the cylinder body
- F_B = Force against the clamping force, e.g. machining forces

Application

Hydro cylinders with locking piston have a relatively little clamping force, but a high retention force in opposite direction. Therefore they are particularly suitable for clamping of thin-walled workpieces with minimum deformation as well as for "floating clamping".

Advantages

- "Clamping" and "Supporting" with one element
- Admissible support force up to five times the clamping force
- Clamping with minimum deformation due to relatively little clamping force, but high retention force
- Particularly suitable for "floating clamping"
- 3 variants of bodies
- Plunger design impedes penetration of fluids into the spring area.
- Spacings between cylinders can be minimised when cylinders are arranged in a row
- Fixtures without tubes are possible



Technical characteristics

Piston Ø	[mm]	20
Stroke	[mm]	10
Oil volume/stroke	[cm ³]	3.14
Min. spring return force	[N]	90
Min. operating pressure	[bar]	50
Recom. pressure range	[bar]	100-500
Seating torque	[Nm]	60
Weight	[kg]	0.25
Part-no.		1462-847
Part-no. additional seal		3000-842

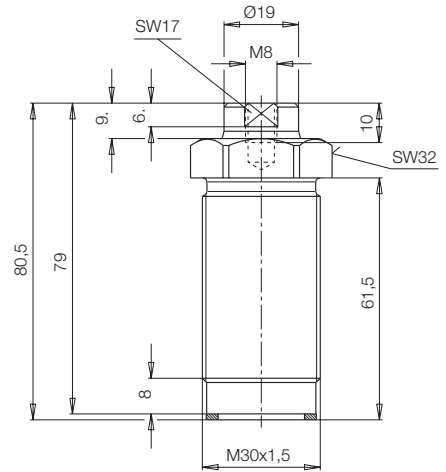

Elastic deformation as a function of the support force of the piston at an operating pressure of 500 bar

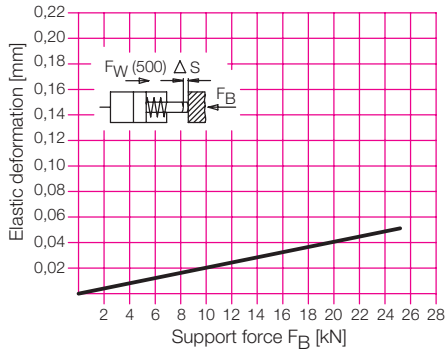

Effective clamping force and admissible load

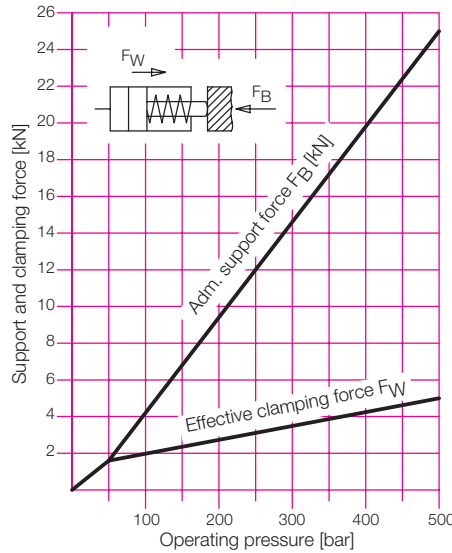

Retention force for "floating clamping"

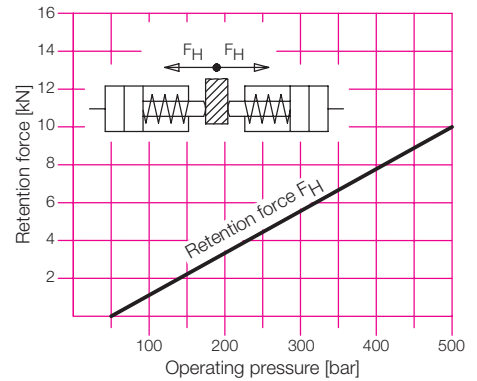

Important notes

Threaded-body cylinders must not be loaded in retracted position. Operating conditions, tolerances and other data see data sheet A 0.100.

In case of "floating clamping" pay attention to an identical stroke of the oppositely-arranged pistons. A difference in stroke of 1 mm causes a difference in clamping force of approx. 5 N.

Porting details

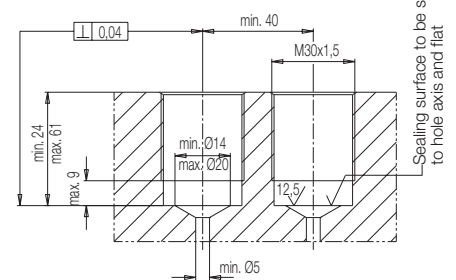

Application example

Simple collet for "floating clamping"

Two clamping bars with **threaded-body cylinders with locking piston** are fixed on a base plate and hydraulically connected by drilled channels. The axial block fixed in the centre is used as guide for both clamping jaws. An installed return spring moves the clamping jaws to its off-position. "Floating" clamping, i.e. the uniform and tongs-type contact at the workpiece independent of its position is possible due to the hydraulic pressure compensation between the cylinders. Only different spring forces can influence the uniformity. After the pressure increase, the two locking pistons avoid a "further floating" of the clamping point.

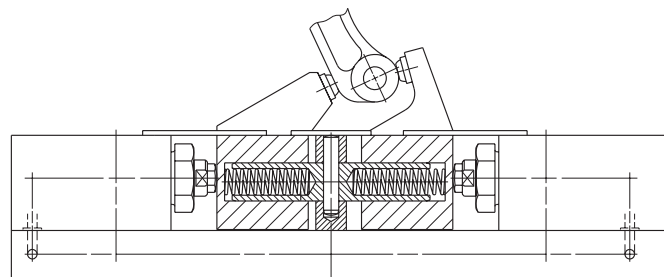



Technical characteristics

Piston Ø	[mm]	20
Stroke	[mm]	10
Oil volume/stroke	[cm ³]	3.14
Min. spring return force	[N]	90
Min. operating pressure	[bar]	50
Recom. pressure range	[bar]	100-500
Weight	[kg]	1.05

Part-no. 1512-801

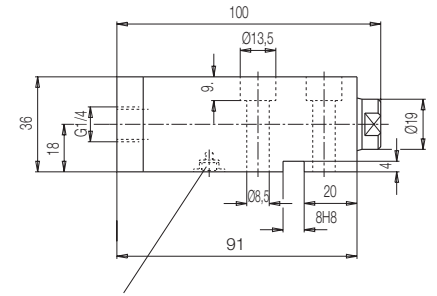

For manifold mounting remove screw with sealing and insert O-ring 9x1,5 (part-no. 3000-345) into the counterbore. Connecting hole max. Ø 7 mm. Screw in plug G 1/4 (part-no. 3610-006).

Elastic deformation as a function of the support force of the piston at an operating pressure of 500 bar

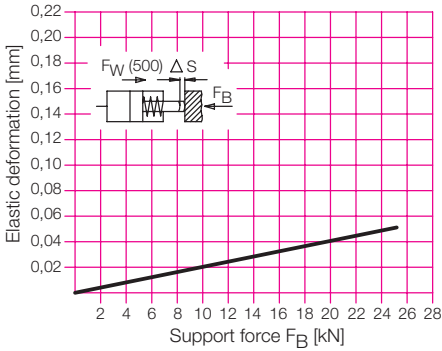

Important notes

In case of "floating clamping" pay attention to an identical stroke of the oppositely-arranged pistons. A difference in clamping stroke of 1 mm causes a difference in clamping force of approx. 5 N.

Effective clamping force and admissible load

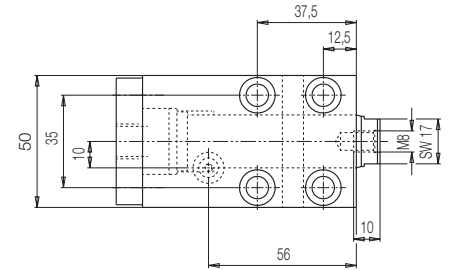
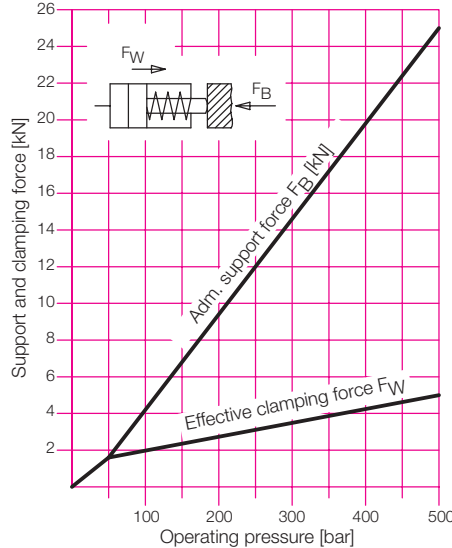

Retention force for "floating clamping"

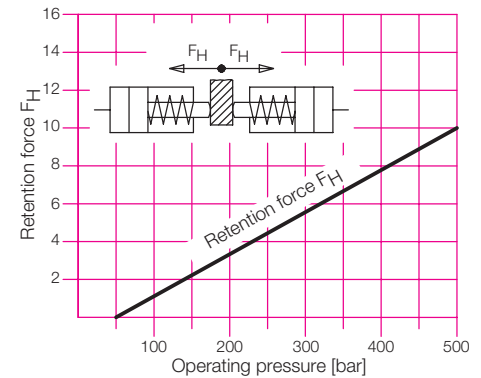

Application example

"Floating clamping"

The workpiece is pre-clamped against the stop and thereby positioned by a standard block cylinder. Then, controlled by a sequence valve, the two **block-cylinders with locking piston** are pressurised. The effective clamping force F_W is uniformly generated by hydraulic pressure at both sides. A "further floating" of the web due to machining forces is avoided due to locking of both pistons. The maximum retention force F_H can be taken from the diagram. This arrangement is particularly suitable to absorb vibrations at ribs and webs.

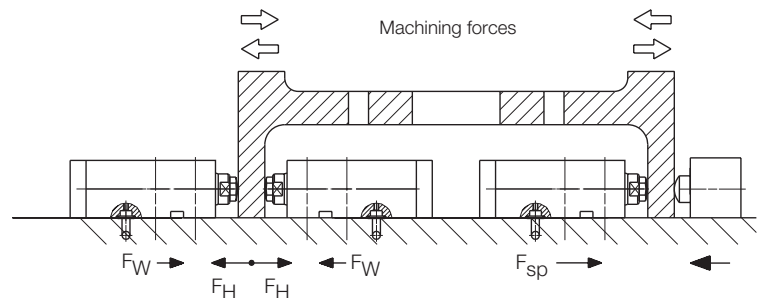



Technical characteristics

Piston Ø	[mm]	20
Stroke	[mm]	10
Oil volume/stroke	[cm ³]	3.14
Min. spring return force	[N]	90
Min. operating pressure	[bar]	50
Recom. pressure range	[bar]	100-500
Weight	[kg]	1.75
Part-no.		1372-800

Accessories/Spare parts

Plug G 1/4		3610-006
Clamping lever, spare part		3542-081
Leg spring, spare part		3715-104

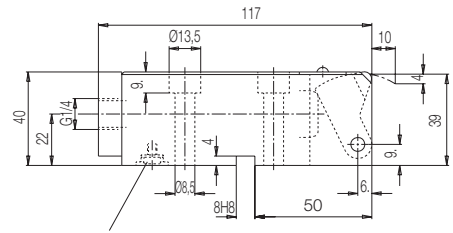

For manifold mounting remove screw with sealing and insert O-ring 10x2 (**part-no. 3000-347**) into the counterbore. Connecting hole max. Ø 7 mm. Screw in plug G 1/4 (**part-no. 3610-006**).

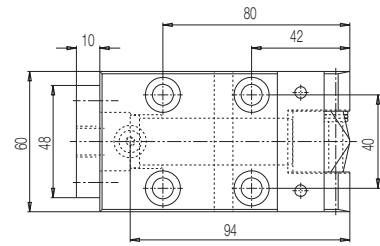

Elastic deformation as a function of the support force of the piston at an operating pressure of 500 bar

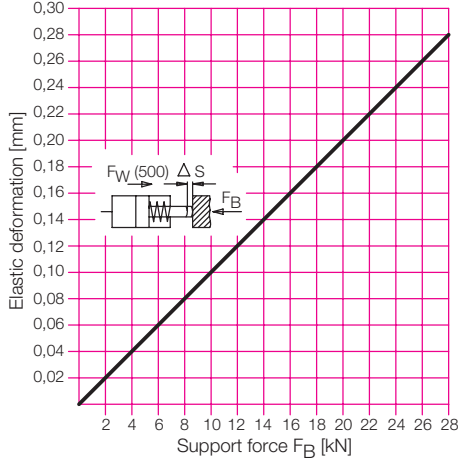

Effective clamping force and admissible load

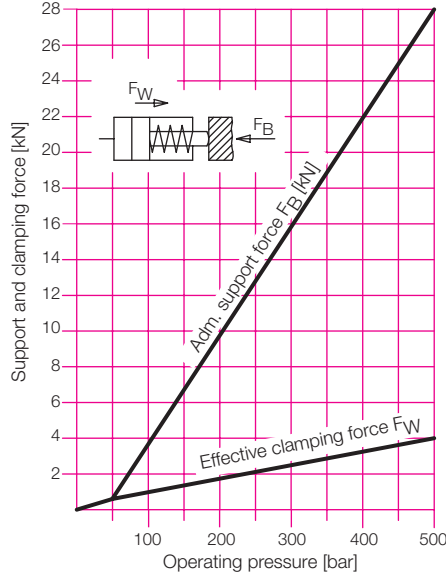

Retention force for "floating clamping"

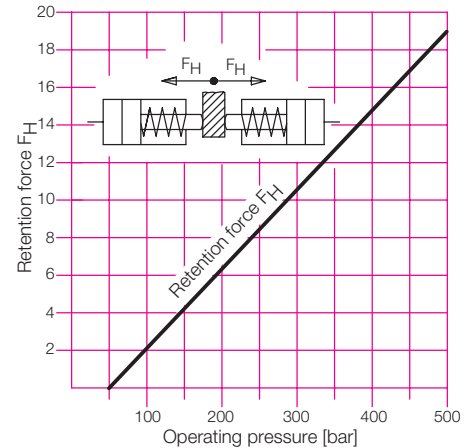

Important notes

In case of "floating clamping" pay attention to an identical stroke of the oppositely-arranged pistons. A difference in stroke of 1 mm causes a difference in clamping force of approx. 5 N.

Application example

Clamping and supporting with minimum deformation

The workpieces are clamped with minimum deformation and relatively little piston force. Since the admissible support force F_B is up to five times higher than the effective clamping force, the clamping forces which act against the right-hand **low-block clamping cylinder with locking piston** are securely compensated. With this arrangement the available machining area at the fixture is optimally used.

