

Hinge Clamps with metallic wiper and optional position monitoring double acting, max. operating pressure 250 bar

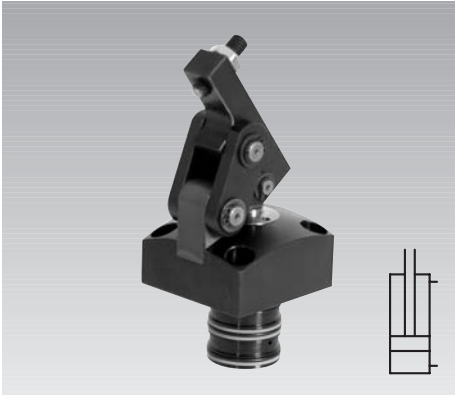

Advantages

- Compact design
- Body partially recessible
- Oil supply alternatively via fitting connections or drilled channels
- Unimpeded loading and unloading of the fixture
- Clamping lever can be swivelled into small recesses
- Clamping possible without side loads
- Long clamping lever adaptable to the workpiece
- Lever mechanism easy to clean
- Standard metallic wiper
- Standard FKM seals
- Inductive or pneumatic control of the clamping position and the clamping range optional

Function

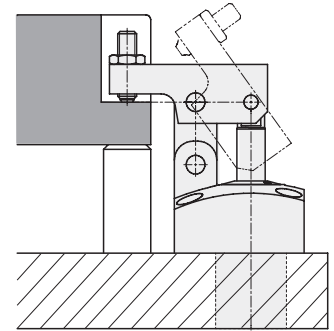

Application

The hinge clamp is a low-cost hydraulic clamping element with many installation and connecting possibilities.

If the clamping lever is completely retracted, unimpeded loading and unloading of the fixture can be effected. A clamping recess in the workpiece a little bit wider than the clamping lever is sufficient as clamping surface.

The special kinematics allow clamping nearly without side loads of workpieces which are very sensitive against deformation.

Description

When pressurising the element, the piston moves upwards and swivels the clamping lever over the hinges forwards and at the same time downwards onto the workpiece. The piston force is deviated by 180° and is available as clamping force with virtually no loss of efficiency.

If the level of the clamping surface is exactly on height h (see page 2), no side loads are introduced into the workpiece. The bodies are recessible in the fixture up to the flange.

Alternatively intermediate plates are available for height adjustment.

All versions are optionally available with extended piston rod and with inductive or pneumatic position monitoring.

Installation and connecting possibilities

Cartridge-type version

for horizontally-drilled channels

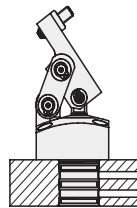

Option

Extended piston rod

for all versions available

without position monitoring

with position monitoring

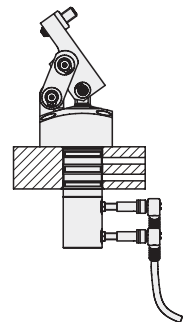
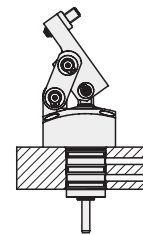

Fitting connection at the back / Pressure oil connector

Fitting connection, at the back

for vertically drilled channels

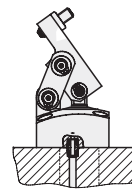
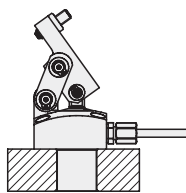

Accessories

Intermediate plates

for all versions with fitting connections

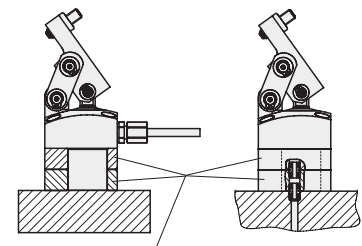

Intermediate plates

Important notes

Hydraulic clamping elements generate big forces. Considerable injuries can be caused to fingers during clamping and unclamping in the effective area of the clamping arm.

Remedy: Protection device with electrical locking.

The hinge clamp has to be checked now and then on contamination by swarf and has to be cleaned, if required.

Operating conditions, tolerances and other data see data sheet A 0.100.

Fitting connections at 3 sides

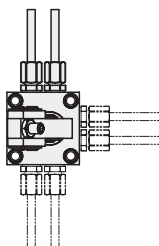

Option

Long clamping lever

available for all versions.

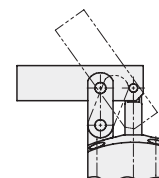

Alternatively all versions are also available without clamping lever.

网址: www.fdzc.net 联系人: 程家雄 手机: 13601809714

联系电话: 021-51872743

E-mail: chengff@sh163.net

Cartridge-type version

Clamping lever with swivel contact bolt

1825-X11

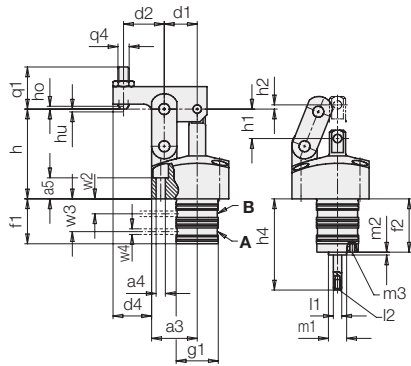

Without clamping lever extended piston rod

1825-X20

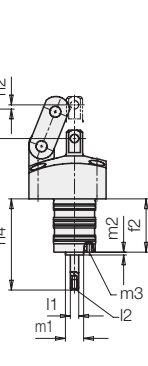

Optionally

with pneumatic position monitoring

1825-X21P

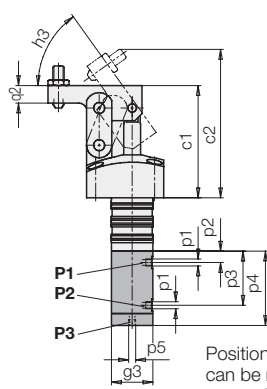

Optionally

with inductive position monitoring and long clamping lever

1825-X22E

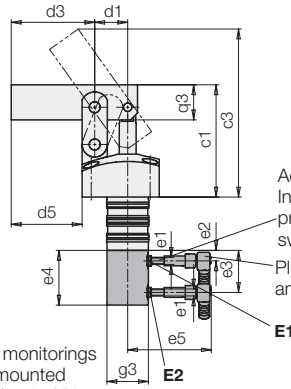

Position monitorings can be mounted turned by 4x 90°

Location hole for cartridge-type version

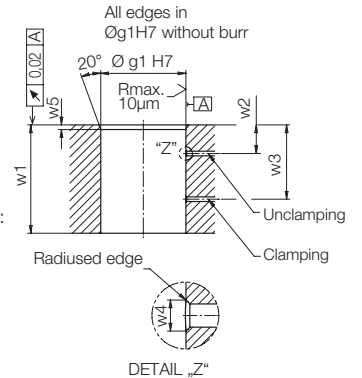

Fitting connection at the back / pressure oil connector

Clamping lever with swivel contact

Without clamping lever extended piston rod bolt

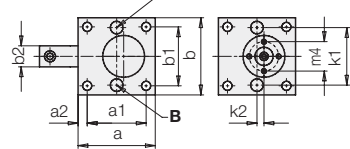

- A** = Clamping
- B** = Unclamping
- E1** = Clamping range, inductive
- E2** = Unclamped, inductive
- P1** = Clamping range, pneum.
- P2** = Unclamped, pneum.
- P3** = Exhaust air, pneum. position monitoring

Accessory:

Intermediate plates for versions with fitting connections

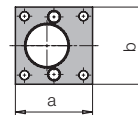

1825-X31

1825-X40

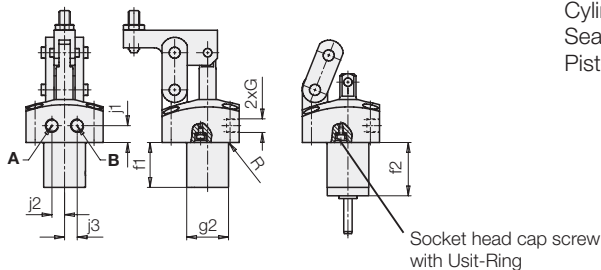

Material

- Cylinder body: steel
- Sealings: FKM
- Piston: high alloy steel

Accessory:

Pressure oil connector

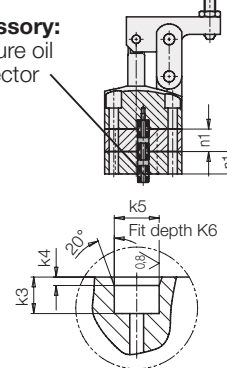

Fitting connections at 3 sides

1825-X51

Clamping lever with swivel contact bolt

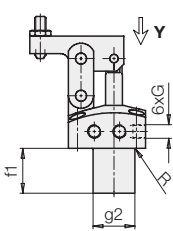

View Y

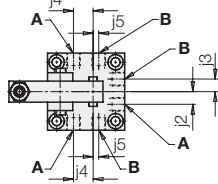

1825-X60

without clamping lever extended piston rod

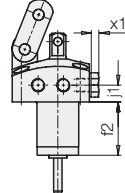

4x screw plug with sealing edge included in the delivery (dimension x1)

For oil supply through pressure oil connectors, these bore holes have to be provided in the base plate
Required accessory when using pressure oil connectors: 2x plugs or 2x screw plugs (see page 4)

Connecting dimensions for self-manufactured clamping levers

Size		1	2	3
d1	[mm]	23.5	33	37
q3	[mm]	25	40	50
s1	[mm]	7	10.5	13
s2	[mm]	Ø8 H7	Ø12 H7	Ø15 H7
s3	[mm]	Ø6 H7	Ø9 H7	Ø12 H7
t1	[mm]	15 -0.1	20 -0.1	25 -0.1
t2	[mm]	9	16.5	20
t3	[mm]	5	8	12
t4	[mm]	5	8	32
u1	[mm]	18	27.5	35.5
u2	[mm]	18	24	31
u3	[mm]	8.1 +0.1	10 +0.1	13 +0.1

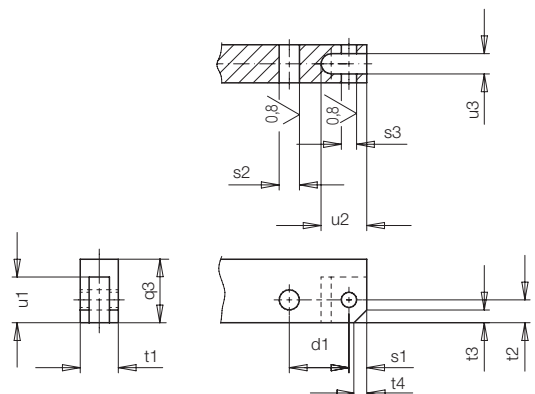

Size		1	2	3
Clamping force at length of clamping lever d2 and 250 bar	[kN]	4.0	10.0	14.2
Clamping force at length of clamping lever d2 and 250 bar with extended piston rod	[kN]	3.4	9.4	13.7
Oil volume clamping	[cm ³]	4.8	16.9	31.1
Oil volume clamping with extended piston rod	[cm ³]	4.1	16.0	30.0
Oil volume unclamping	[cm ³]	2.1	10.0	19.0
Max. oil flow rate	[cm ³ /s]	15.7	24.5	24.5
a	[mm]	55	70	85
a1	[mm]	42	56	69
a2	[mm]	6.5	7	8
a3	[mm]	32.5	46	52
a4	[mm]	4 x Ø 6.6	4 x Ø 9	4 x Ø 11
a5	[mm]	15	18	21.5
b	[mm]	55	70	85
b1	[mm]	42	56	69
b2	[mm]	15	20	25
c1	[mm]	80	116	143
c2	[mm]	106	150	185
c3	[mm]	120	171	208
d1	[mm]	23.5	33	37
d2	[mm]	29	39.5	49
d3	[mm]	59.5	81.5	98
d4	[mm]	27.5	37.5	47.5
d5	[mm]	50.5	68.5	83
e1		M5 x 0.5	M5 x 0.5	M5 x 0.5
e2	[mm]	7.5	9.7	11.6
e3	[mm]	30	41.9	46
e4	[mm]	39	49	55
e5	[mm]	approx. 60	approx. 60	approx. 60
f1	[mm]	32	43	44.5
f2	[mm]	38	49	50.5
G		G 1/8	G 1/8	G 1/4
Max. size of connecting fitting (see data sheet F 9.300)		6 L	8 S	10 L
g1	[mm]	Ø 30 f7	Ø 42 f7	Ø 52 f7
g2	[mm]	Ø 29.8	Ø 41.8	Ø 51.8
g3	[mm]	Ø 29.5	Ø 39	Ø 39
h	[mm]	64	92.5	113
ho	[mm]	2	2.7	3.5
hu	[mm]	2	2.7	3.5
h1	[mm]	21	30	33.5
h2	[mm]	3	4.5	5.2
h3	[°]	54.5	55.5	56
h4	[mm]	65	86.5	93
j1	[mm]	12	16	17
j2	[mm]	9	13.5	15.5
j3	[mm]	9	13.5	15.5
j4	[mm]	14	20	25
j5	[mm]	4	2	6
k1	[mm]	41 ±0.02	55 ±0.02	68 ±0.02
k2	[mm]	5 ±0.05	0 ±0.05	0 ±0.05
k3	[mm]	6.5	6.5	6.5
k4	[mm]	1.5	1.5	1.5
k5	[mm]	Ø 8 H7	Ø 8 H7	Ø 8 H7
k6	[mm]	5.5	5.5	5.5
l1	[mm]	Ø 6 f7	Ø 6 f7	Ø 6 f7
l2		M4 x 7.5 deep	M4 x 7.5 deep	M4 x 7.5 deep
m1	[mm]	Ø 13 f7	Ø 13 f7	Ø 13 f7
m2	[mm]	2	2	2
m3		M4 x 6 deep	M4 x 6 deep	M4 x 6 deep
m4	[mm]	21	27	27
n1	[mm]	16	21.5	22.5
p1	[mm]	M5	M5	M5
p2	[mm]	8.5	10.6	12.3
p3	[mm]	38.6	50.9	55.1
p4	[mm]	53	73	77
p5		M5	G1/4	G1/4
q1	[mm]	30	40	50
q2	[mm]	12.5	20	25
q3	[mm]	25	40	50
q4		M8	M12	M16
R	[mm]	0.8	0.8	1
w1	[mm]	min. 31.5	min. 41.5	min. 43.5
w2	[mm]	10.6	14.3	14.8
w3	[mm]	23.4	30.7	31.9
w4	[mm]	max. Ø 4	max. Ø 5.5	max. Ø 5.5
w5	[mm]	2.5 - 0.5	2.5 - 0.5	2.5 - 0.5
x1	[mm]	7	7	8

Clamping force F_{max} as a function of the length of the clamping lever d_2 and maximum operating pressure p_{max} .

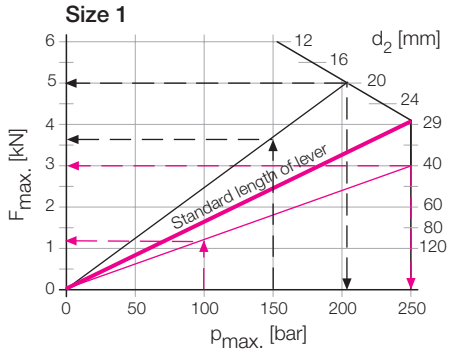

Clamping force with extended piston rod = $0.86 \times F$

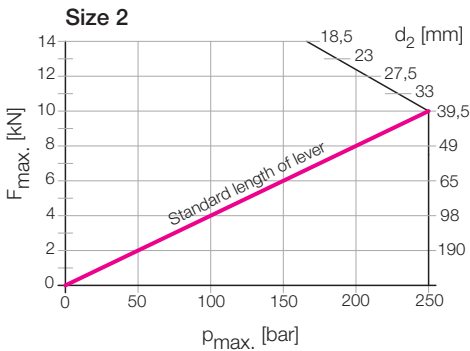

Clamping force with extended piston rod = $0.94 \times F$

Example 1:

Given: Length of clamping lever $d_2 = 40$ mm
Operating pressure $p = 100$ bar

Searched: Clamping force $F_{max} = 3$ kN
As per diagram: $p_{max} = 250$ bar

Solution: Clamping force $F = F_{max} \frac{p}{p_{max}} = 3 \text{ kN} \frac{100 \text{ bar}}{250 \text{ bar}} = 1.2 \text{ kN}$

Example 2:

Given: Length of clamping lever $d_2 = 20$ mm
Operating pressure $p = 150$ bar

Searched: Clamping force $F_{max} = 5$ kN
As per diagram: $p_{max} = 210$ bar

Solution: Clamping force $F = F_{max} \frac{p}{p_{max}} = 5 \text{ kN} \frac{150 \text{ bar}}{210 \text{ bar}} = 3.57 \text{ kN}$

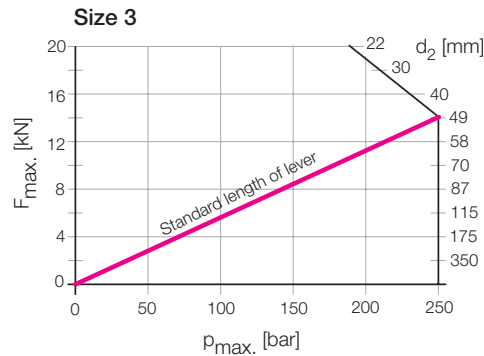

Clamping force with extended piston rod = $0.96 \times F$

Code for part numbers

1825 - X X X X

Basic type

- 1 = Size 1
- 2 = Size 2
- 3 = Size 3

- 1 = cartridge-type version
- 2 = cartridge-type version with extended piston rod *)
- 3 = fitting connection at the back / pressure oil connector
- 4 = fitting connection at the back / pressure oil connector with extended piston rod *)
- 5 = fitting connections at 3 sides
- 6 = fitting connection at 3 sides with extended piston rod *)

- 0 = without clamping lever
- 1 = clamping lever with swivel contact bolt
- 2 = long clamping lever, unmachined

Material: steel

*) Condition for mounted position monitoring (addition: E or P)

Accessories - part numbers

Size	1	2	3
Intermediate plate (not for cartridge-type version)	3456-449	3456-468	3456-489
Pressure oil connector	9210-145	9210-145	9210-145
Plug, flush screwable with hexagon socket	0361-986	0361-986	0361-987
Screw plug with hexagon head	3610-008	3610-008	3610-006
Pneumatic position monitoring, complete **)	0353-845	0353-853	0353-855
Inductive position monitoring, (without inductive proximity switch **)	0353-846	0353-854	0353-856
Inductive proximity switch	3829-198	3829-198	3829-198
Plug and cable for inductive proximity switch	3829-099	3829-099	3829-099

Technical characteristics for inductive proximity switches 3829-198

Operating voltage U_B	10 ... 30 V DC
Switching function	Interlock
Output	PNP
Body material	Stainless steel
Protection as per DIN 40050	IP 67
Environmental temperature	-25 ... +70 °C
Connection	Connector/Plug
LED Function display	yes
Constant current max.	150 mA
Rated operating distance	0.8 mm
Protected against short circuits	yes