

## Power Unit for double-acting cylinders with proportional pressure adjustment for automatic press-in force control

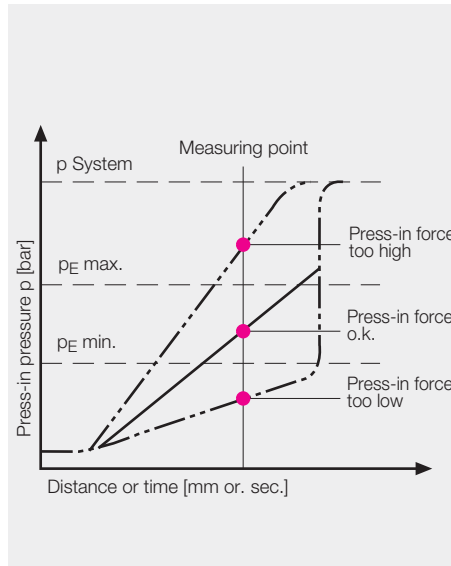
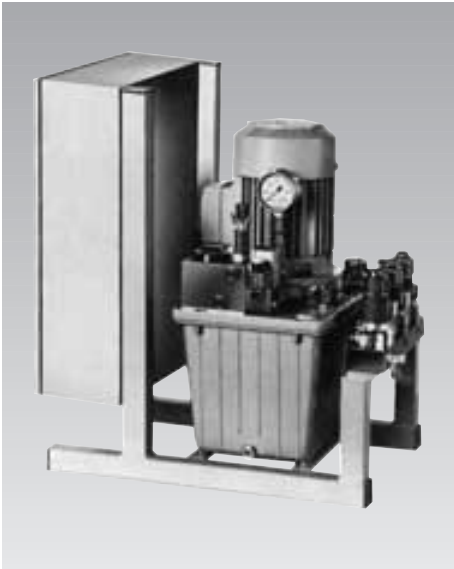

### Technical data

- max. operating pressure 200 and 500 bar
- 10 pre-programmed pressure stages
- limit values adjustable
- potential-free contacts for signal output
- serial interface for documentation of digital value on printer (option)
- measuring time adjustable (max. 5 sec.)
- flow rate 4.5 and 0.9 l/min (other flow rates are available on request)
- proportional control
- programmable control
- reservoir volume: 11 l
- hydraulic oil: HLP 22
- electric oil level control
- electric oil temperature control
- voltage: 400 V 50Hz
- valve and control voltage 24V DC
- control: two-hand safety control, alternately: by inputs of an overriding control (on request)

### Application

When pressing in bushings and similar parts a control of the press-in force is often desired due to quality reasons. The visual control of the press-in force, which is still effected today, is due to the inertia of the indication instruments in most cases inexact and is not reliable in case of short press-in processes.

### Function

Pressure adjustment at the power unit is made by a proportional pressure relief valve.

#### - Pressure stages

The pressure range is divided in 10 stages. The pressures are preselected by means of a 10-stage switch. The values of the pressure stages (see reverse) are programmed by means of the software. If desired, they can be changed later.

#### - Limit values

The limit values are assigned separately to each pressure stage. Adjustment is made by means of a potentiometer in the electric control box from which the pressures can be read directly. The pressures are stored by the push-buttons for the upper and lower limit value.

The limit values can be changed at any time. A key-lock switch is installed for protection against unauthorized adjustment. The determined mode is indicated by pilot lights and can be provided to external controls by potential-free contacts. The version with serial interface allows digital documentation of the measured value by means of a printer.

#### - Measuring point

The point at which pressure shall be controlled can be determined either as a function of time or of the distance. Determination of the measuring point as a function of time is possible if the press-in times are longer than 0.2 sec. The time is also adjusted by the potentiometer in the electric control box and can be selected individually for each pressure stage and is stored by a push-button. The time is started by the pressure increase occurring inevitably at the beginning of the press-in process. The determination of the measuring point as a function of the distance is effected by a limit switch which is adjusted to the desired measuring point.

### Application example

The figure shows a variable press-in fixture.

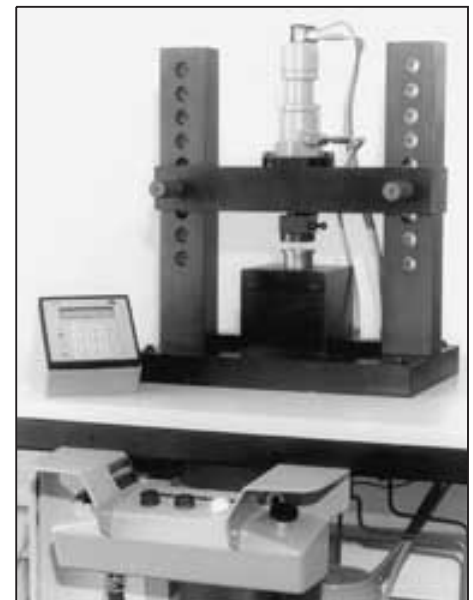

### Two-hand safety control

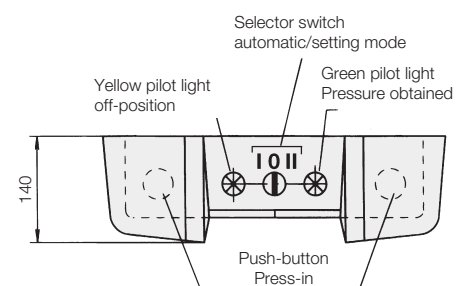
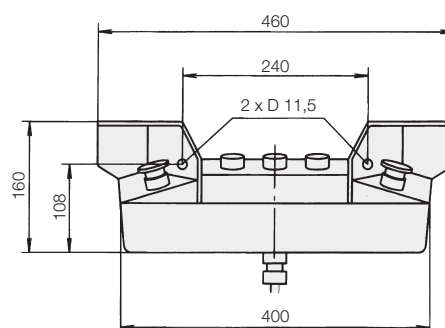

网址: [www.fdzc.net](http://www.fdzc.net) 联系人: 程家雄 手机: 13601809714

联系电话: 021-51872743

E-mail: [chengff@sh163.net](mailto:chengff@sh163.net)

### Hydraulic power unit

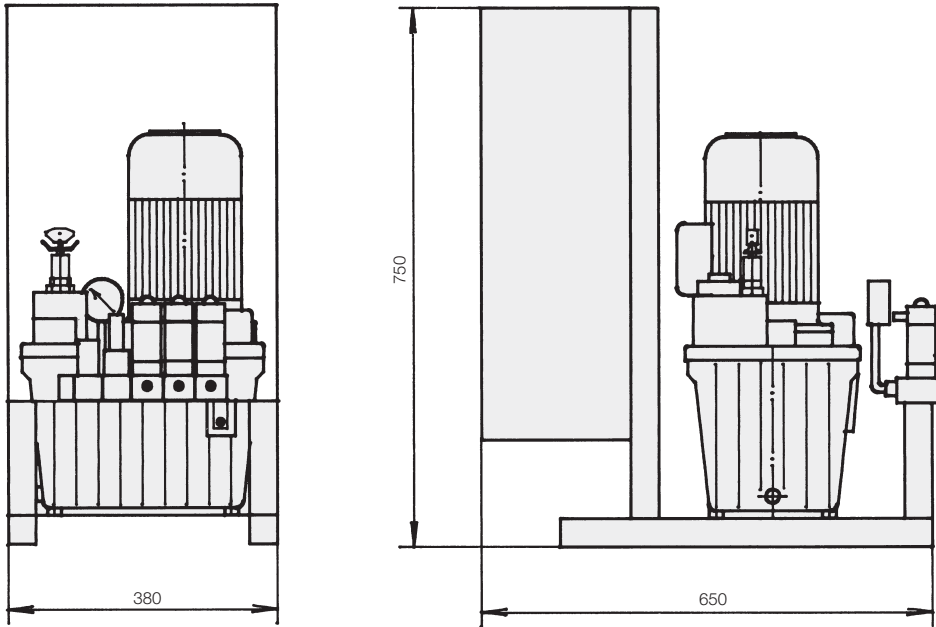

Hydraulic power unit	Flow rate l/min	Pressure bar	Rating	Part-no.
<b>with two-hand safety control</b>	0.9	500	0.75	<b>6821-010</b>
	4.5	200	1.5	<b>6829-010</b>
<b>with two-hand safety control and serial interface</b>	0.9	500	0.75	<b>6821-210</b>
	4.5	200	1.5	<b>6829-210</b>

For documentation the measured values can be printed as shown below on a EPSON-compatible printer, which is directly connected to the serial interface:

```

*****
Part-no.  0...65 535
Date (08.02.91)      Time:      (16:34:15)
Lower limit value:   (80)        bar
Upper limit value:   (160)       bar
Time:                (300)       1/100 sec.
Nominal pressure:    (140)       bar
*****
    
```

Hydraulic circuit diagram with  
proportional pressure adjustment

