

Hydraulic Pump manually operated max. operating pressure 100, 200 and 500 bar

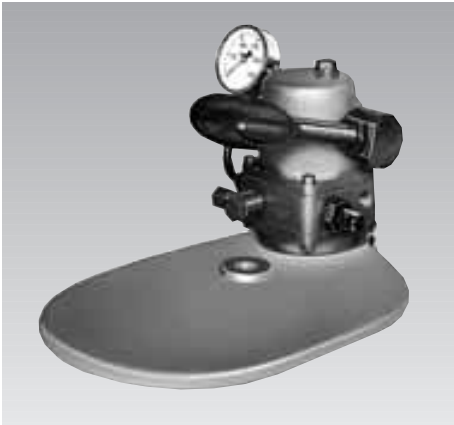

Types 8804-006, 8805-006, 8816-006

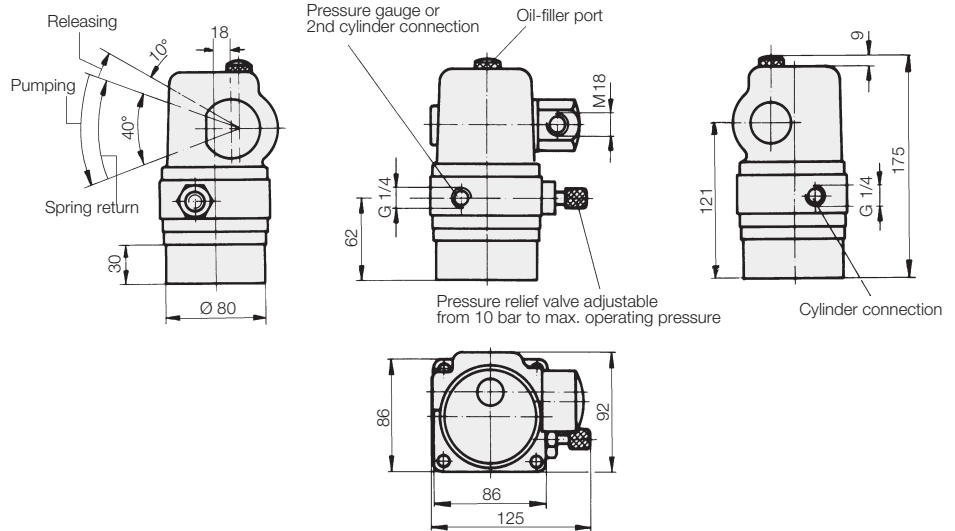

Type with foot lever, base and pressure gauge

In connection with our clamping elements, workpieces can be clamped economically with this clamping pump.

Furthermore, this pump can be used for lifting loads, adjusting and clamping tables, as well as for other operating processes.

The particular advantages of this pump are:

- Choice of hand or foot operation
- Pumping and releasing with the same lever
- Continuously adjustable pressure relief valve
- Metallic seal on pump piston, thereby nearly wear-free
- Compact, self-contained design.

Delivery without accessories.

Hydraulic lifting pumps with safety hand or foot lever are assembled and ready for operation.

Accessory see page 2.

Types 8806-006 and 8807-006

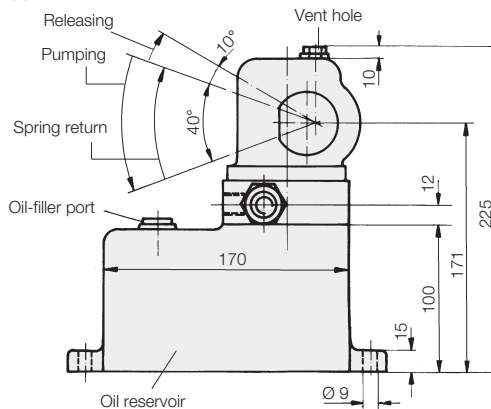

Type 8808-006

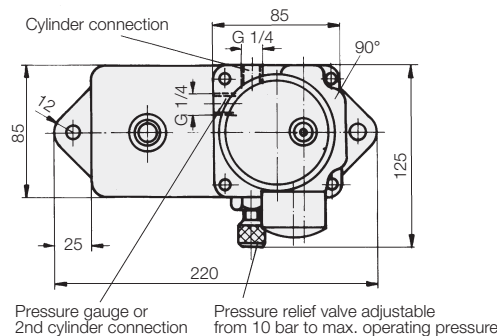
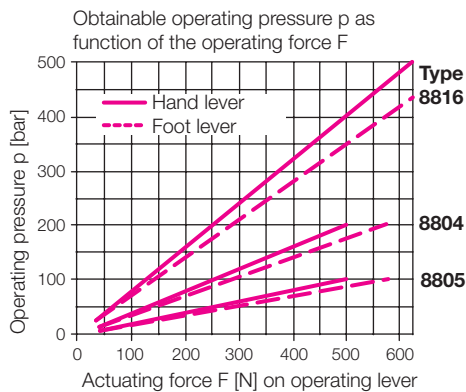
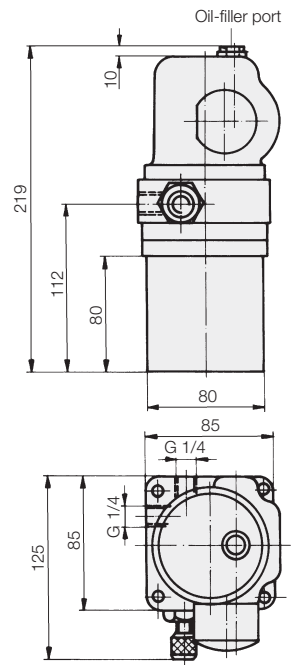

Max. operating pressure	[bar]	200	100	500	100	200	200
Oil volume	[cm ³]	300	300	300	970	970	400
Available oil volume	[cm ³]	150	150	150	750	750	250
Displacement per stroke	[cm ³]	4	8	2	8	4	4
Weight	[kg]	6.1	6.1	6.1	9.5	9.5	6.4
Part-no. (without accessory)		8804-006	8805-006	8816-006	8806-006	8807-006	8808-006

网址: www.fdzc.net 联系人: 程家雄 手机: 13601809714

联系电话: 021-51872743

E-mail: chengff@sh163.net

The following accessories with connecting fittings for the hydraulic pump must be ordered separately:

For pump type	8804-006	8805-006	8816-006	8806-006	8807-006	8808-006
Base plate	Part-no. 3533-001	3533-001	3533-001	-	-	3533-001
Bracket	Part-no. 3533-002	3533-002	3533-002	-	-	3533-002
Flange	Part-no. 3533-003	3533-003	3533-003	-	-	3533-003
Foot lever	Part-no. 0990-102	0990-102	0990-102	0990-102	0990-102	0990-102
Hand lever	Part-no. 0990-103	0990-103	0990-103	0990-103	0990-103	0990-103
Pump unit with safety hand lever	Part-no. 8804-026	8805-026	8816-026	8806-026	8807-026	8808-026
Pump unit with safety foot lever	Part-no. 8804-016	8805-016	8816-016	8806-016	8807-016	8808-016
High-pressure hose NW 6x1600	Part-no. 9320-621	9320-621	9370-621	9320-621	9320-621	9320-621
Pressure gauge with 90° elbow 0-250 bar	Part-no. 9811-015	9811-015	-	9811-015	9811-015	9811-015
Pressure gauge with 90° elbow 0-600 bar	Part-no. -	-	9811-017	-	-	-
Hydraulic oil HLP 32, 1l container	Part-no. 9895-001	9895-001	9895-001	9895-001	9895-001	9895-001

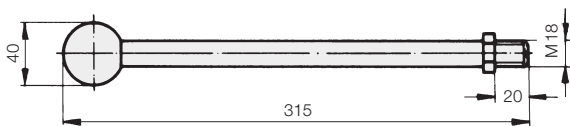
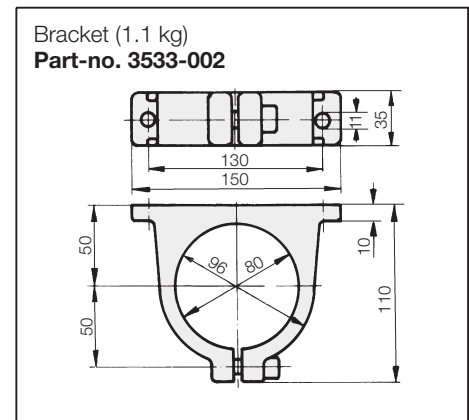
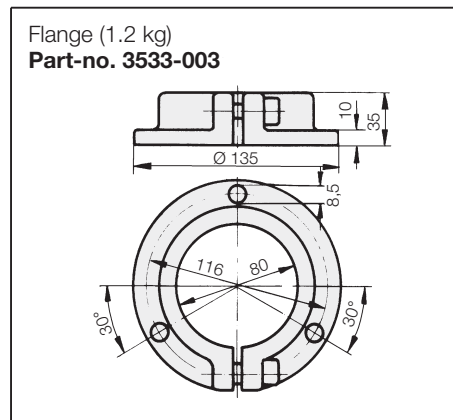
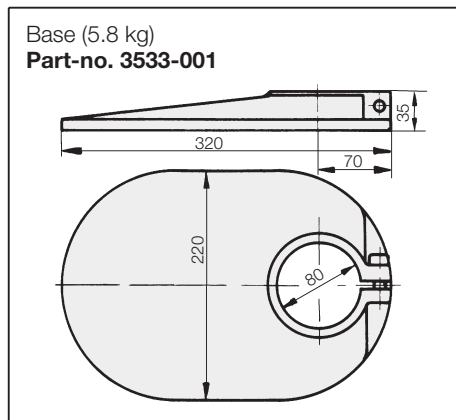

Hand lever
Part-no. 0990-103

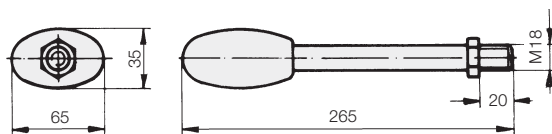

Foot lever
Part-no. 0990-102

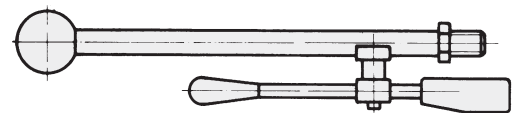

Safety hand lever *

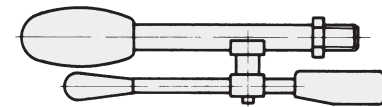

Safety foot lever *

* Delivery only together with hydraulic pump (see table)

Principle of a hydraulic clamping pump with hydraulic cylinder

Manually operated hydraulic clamping pump

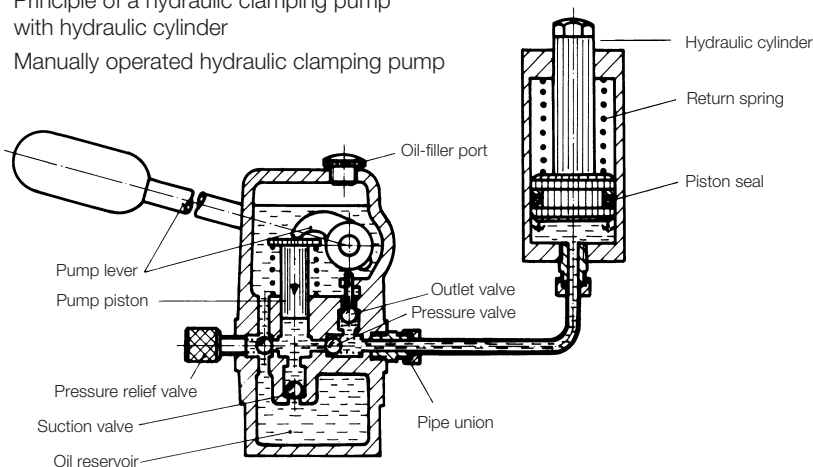

Example for ordering

Hydraulic clamping pump with accessories, 8 cm³ displacement, 100 bar operating pressure

Hydraulic clamping pump	8805-006
Foot lever	0990-102
Base	3533-001
High-pressure hose	9320-621
Gauge with 90° elbow	9811-015
Hydraulic oil	9895-001

The pump supplied filled with oil.