

Two-Stage Hydraulic Pump with automatic change-over from low stage 60 bar to high stage 500 bar

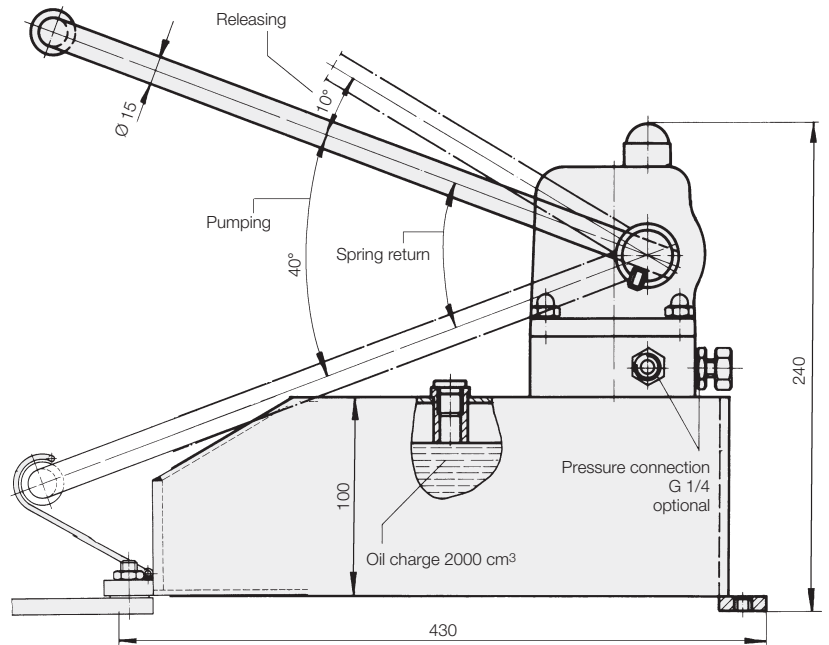

Two-stage pump, usable oil volume 1800 cm³

Part-no. 8817-000



Description

The pump is designed to operate single-acting cylinders and is fitted with a differential piston. Changing from low pressure to high pressure is automatic. An externally adjustable pressure relief valve is standard equipment. Pumping as well as releasing is controlled by the same lever and can be done by hand or foot.

The operating lever is held in the released position by a spring loaded detent.

The operating lever can be held in the lowest position by a retaining clip, so that the device can be easily carried by hand.

Hydraulic circuit diagram

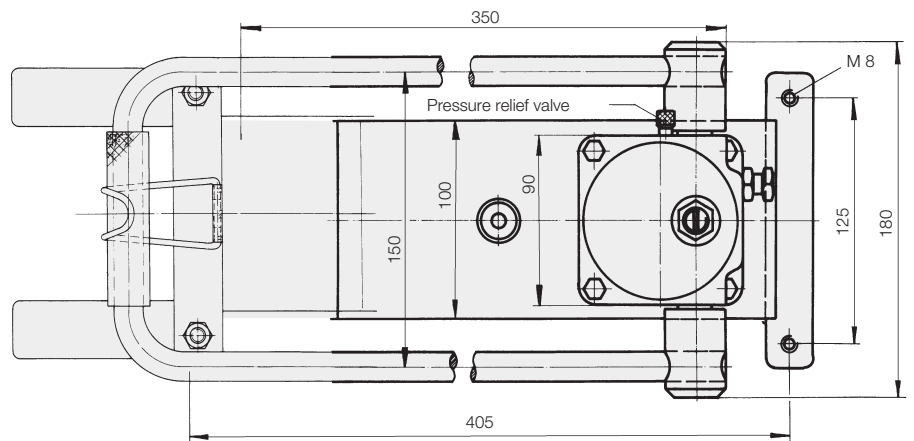
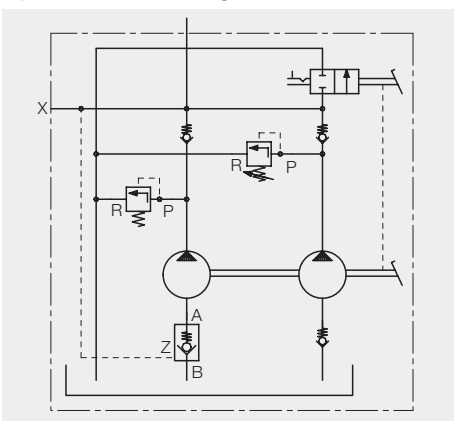

Displacement/stroke	up to 60 bar	[cm ³]	12	12	12
	up to 500 bar	[cm ³]	2.4	2.4	2.4
Usable oil volume		[cm ³]	1800	800	200
Range of adjustment, pressure relief valve		[bar]	50-500	50-500	50-500
Actuating force	up to 60 bar	[N]	216	216	216
	up to 500 bar	[N]	360	360	360
Weight, without oil		[kg]	10.5	11.5	9.8

Part-no. 8817-000 8817-002 8817-003

Dimensional drawings and accessories for part-no 8817-002 and 8817-003 see reverse page

网址: www.fdzc.net 联系人: 程家雄 手机: 13601809714

联系电话: 021-51872743

E-mail: chengff@sh163.net

Two-stage pump, usable oil volume 800 cm³

Part-no. 8817-002

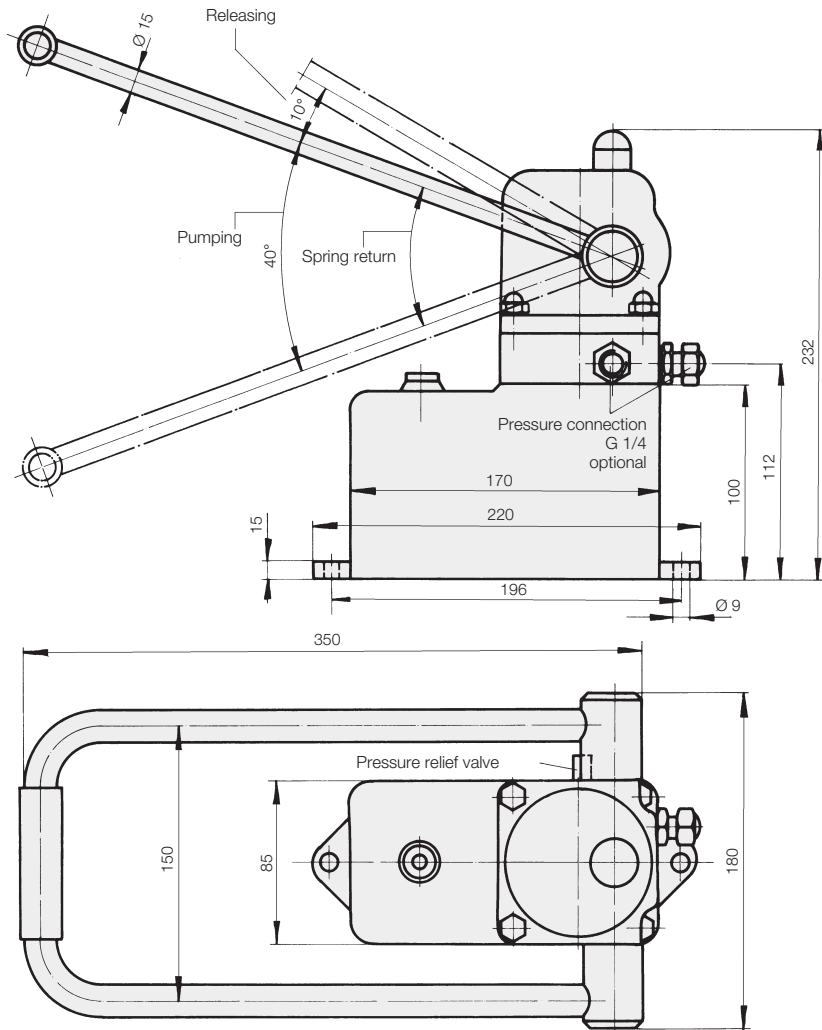

Two-stage pump, usable oil volume 200 cm³

Part-no. 8817-003

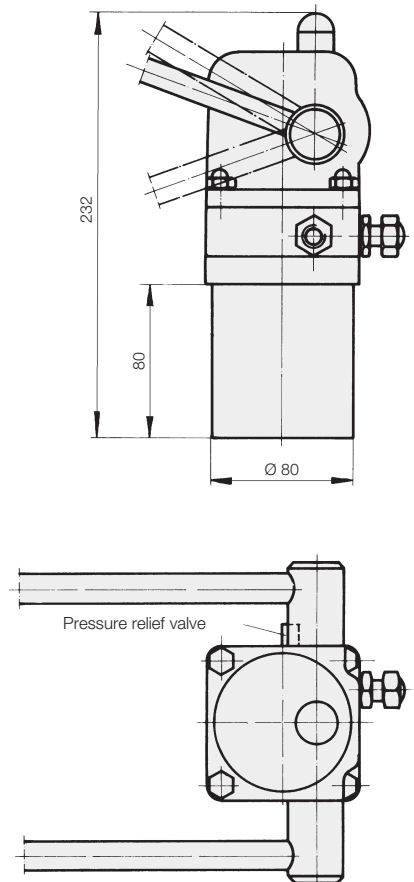

Accessories

There are 3 different mounting possibilities for the pump 8817-003 (see photos and drawings)



Bracket (1.1 kg) **Part-no. 3533-002**

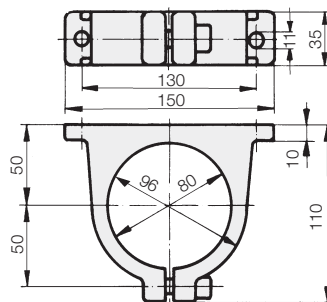

Base (5.8 kg) **Part-no. 3533-001**

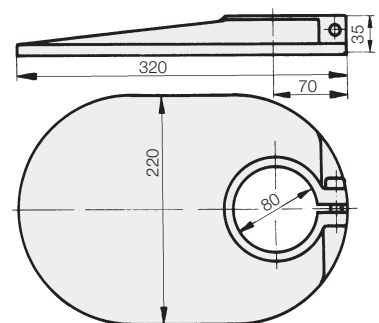

Flange (1.2 kg) **Part-no. 3533-003**

