

Concentric Positioning and Clamping Elements

with variable range of clamping, hydraulically or mechanically operated double-acting, max. operating pressure 500 bar

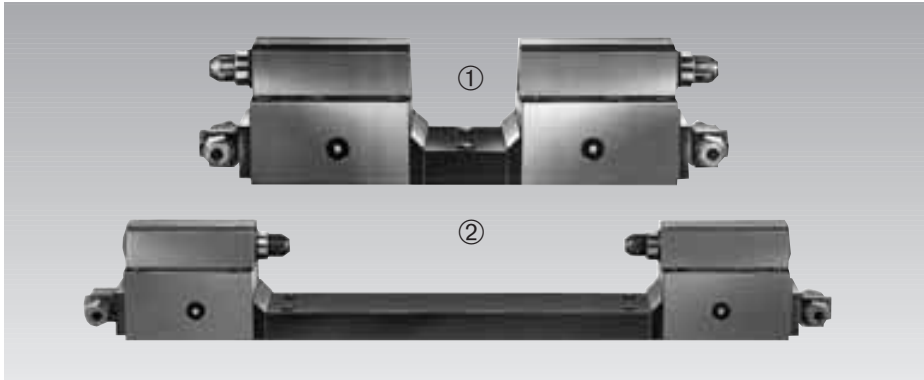

Figures

- ① Double clamping element for concentric interior clamping
- ② Double clamping element with prolonged connecting bar for exterior clamping
- ③ By means of the double clamping elements modular fixtures can be composed which position and clamp concentrically in several dimensions, e.g. in direction of the x- and y-axis.
- ④ Double clamping element for exterior clamping, mechanically operated. Operation is effected by a torque wrench. For operating torque see chart on page 3.

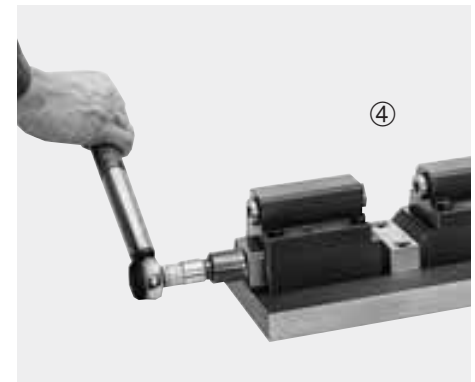
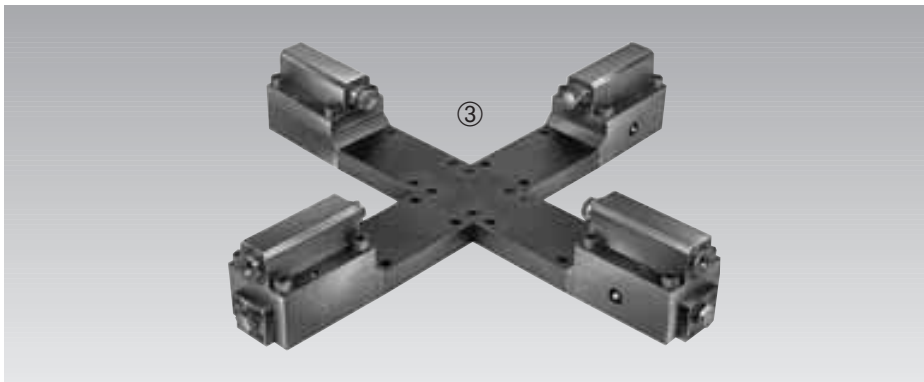

Description

Concentric positioning and clamping with two or three-jaw chucks on stationary fixtures is nothing new. In many applications, however, it is not possible to place the relatively large chuck bodies on the fixture. Often the small clamping strokes are an additional obstacle.

In our new development, the individual parts can be connected to a two-jaw or a multiple-jaw version. Interior and exterior clamping is possible. In the multiple-jaw version each pair of jaws clamps independently of the remaining ones, thereby concentric clamping is obtained. The opening can be determined by means of a connecting bar. The clamping strokes of the several sizes are designed such that manual or automatic loading and unloading can be effected also to clamp blanks with large tolerances. Single-acting elements are available on request.

Clamping possibilities

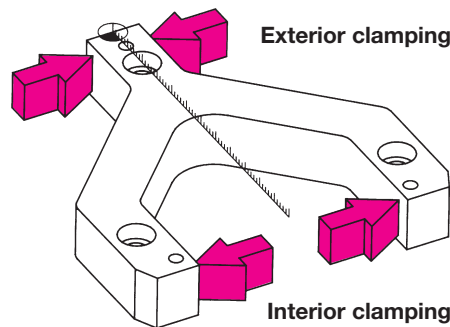

Application example

The flexible clamping unit is used to clamp bars which can be machined in every position, e.g. drilled, milled, threaded, etc. In conjunction with a pneumatic two-jaw chuck the rotary indexing table is used to determine the machining position of the workpiece. The two-jaw chuck and the right-hand concentric clamping element keep the bars in the exact working position. The floating clamping elements support the clamping stability.

Active principle

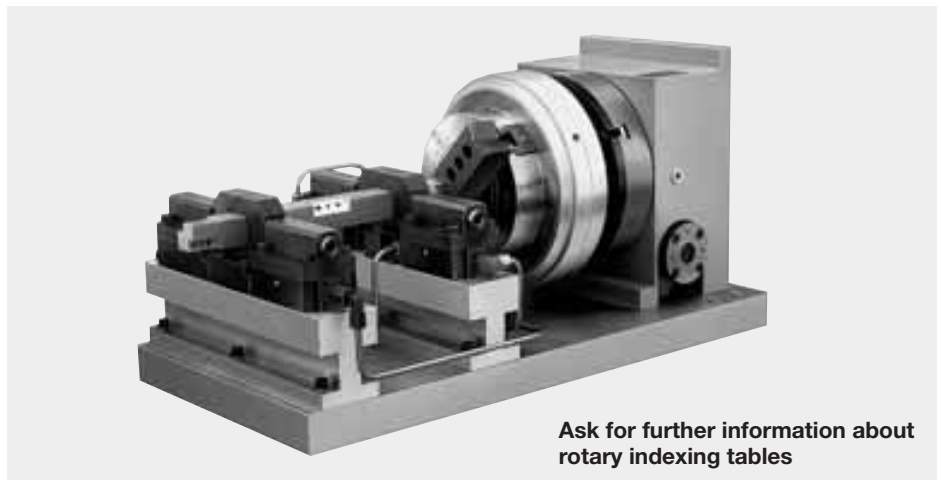
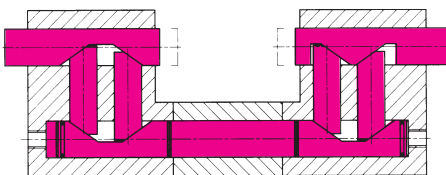

Ask for further information about rotary indexing tables

网址: www.fdzc.net 联系人: 程家雄 手机: 13601809714

联系电话: 021-51872743

E-mail: chengff@sh163.net

Hydraulic elements for concentric clamping

- Interior clamping

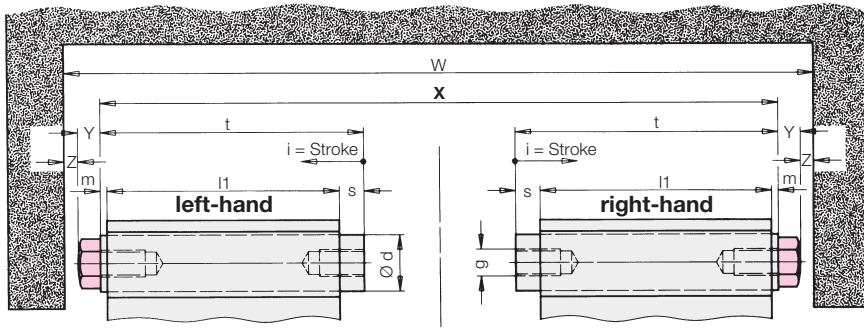

- Exterior clamping

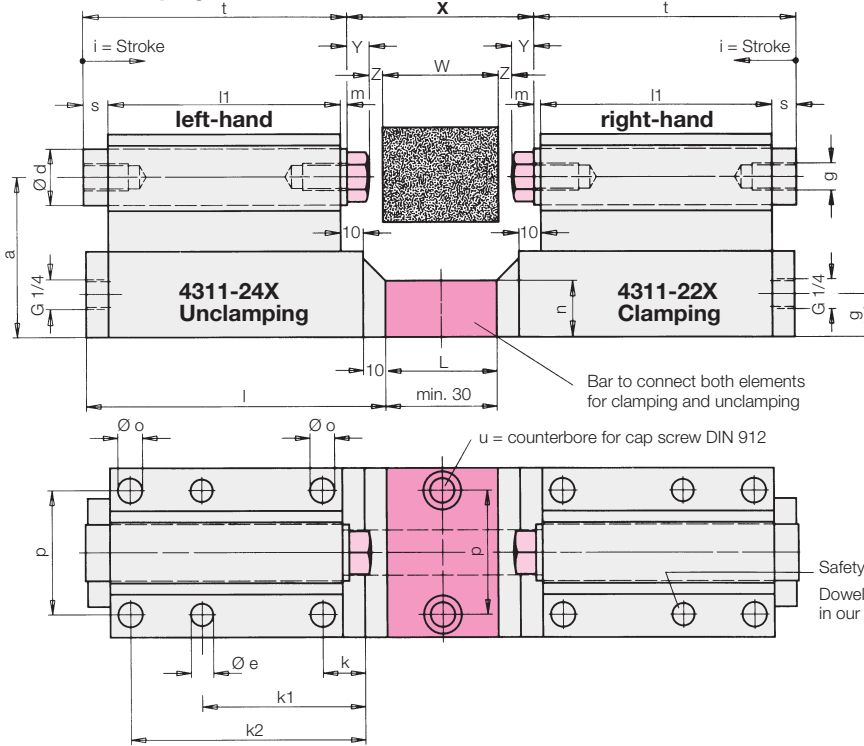

Remarks for ordering

Please indicate on your order the required workpiece length, the tolerance as well as the contact bolt.

Interior clamping

$$X = W - 2Z - 2Y$$

Exterior clamping

$$X = W + 2Z + 2Y$$

W = Workpiece

Z = Idle stroke

Y = Contact bolt*

X = Order dimension

X_{min} , see table

$$L = X - X_{min} + 30$$

* Contact bolts see data sheet G 3.800

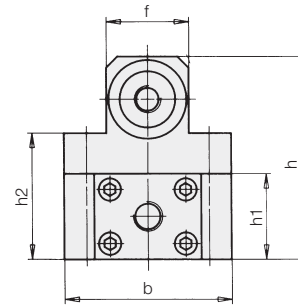

Mechanical elements for concentric clamping

- Exterior clamping

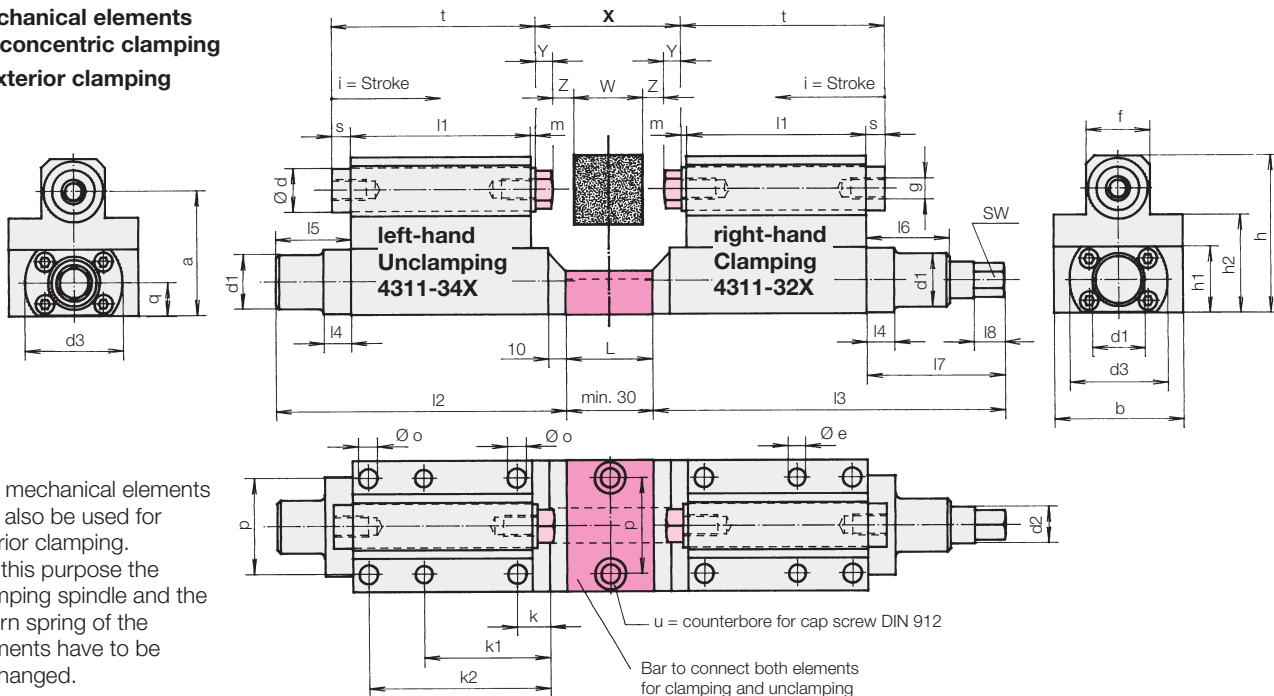

The mechanical elements can also be used for interior clamping. For this purpose the clamping spindle and the return spring of the elements have to be exchanged.

art-nos.
Crossing for 3 elements
Crossing for 4 elements

Repetitive accuracy of clamping force ± 0.005 mm

Clamping force per pair of elements	[kN]	5	12	20
at max. operating pressure	[bar]	500	500	500
at max. torque	[Nm]	12	34	62
a centre height	[mm]	52	71	87
Larger centre heights on request				
b	[mm]	62	75	86
Piston/bolt \varnothing d	[mm]	16	25	32
d1	[mm]	21.5	30.5	35
d2	[mm]	15	21	25
d3	[mm]	45	57	70
e \varnothing	[mm]	8 H7	10 H7	12 H7
f	[mm]	28	37	45
g	[mm]	M8 x 18	M12 x 30	M16 x 22
h	[mm]	66	90	111
h1	[mm]	27	38	47
h2	[mm]	41	56	72
i Clamping stroke	[mm]	6	8	8
k	[mm]	18.5	19	22.5
k1	[mm]	58.5	73	81.5
k2	[mm]	83.5	105	117.5
k3	[mm]	12	15	18
k4	[mm]	22	30	35
k5	[mm]	32	40	50
l	[mm]	117	134	152
l1	[mm]	82	104	120
l2	[mm]	152	168	185
l3	[mm]	165	204	231
l4	[mm]	13	16	20
l5	[mm]	50	44	45
l6	[mm]	38	48	56
l7	[mm]	63	80	91
l8	[mm]	14	18	21
m	[mm]	2	3	3
n	[mm]	20	25	30
o \varnothing	[mm]	9	11	13
p	[mm]	45	55	65
p1	[mm]	40	52	60
p2	[mm]	68	86	100
q	[mm]	14	19	24
r	[mm]	15	10	10
s	[mm]	8	11	11
t	[mm]	92	118	134
u	[mm]	M8	M10	M12
v	[mm]	10	10	10
X _{min.}	[mm]	66	64	64
X _{3min.}	[mm]	148.4	166	186
X _{4min.}	[mm]	138	149	170
L _{min.}	[mm]	30	30	30
L _{3min.}	[mm]	24.2	26	26
L _{4min.}	[mm]	20	20	25
SW	[mm]	13	17	19
Weight	[kg]	2.2	4.5	9

Crossing for 3 elements

$$X3 = W + 2Y + 2Z$$

X_{3min.} see table

Size 1 (\varnothing 16)

$$L3 = X3/2 - 50$$

Size 2 (\varnothing 25)

$$L3 = X3/2 - 57$$

Size 3 (\varnothing 32)

$$L3 = X3/2 - 67$$

For exterior clamping
 2 elements 4311-22X
 1 element 4311-24X
 and
 3 connecting bars L3
 are required, the
 connecting bars must
 always have the same
 length.

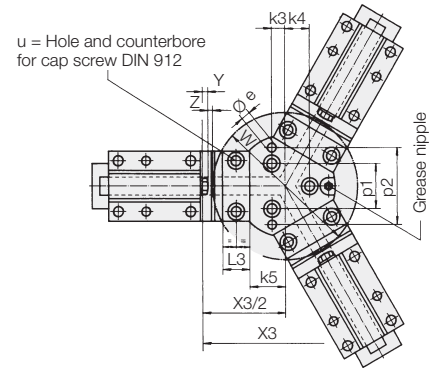

Crossing for 4 elements

$$X4 (a/b) = W + 2Y + 2Z$$

X_{4min.} see table

Size 1 + 2

$$L4 (a/b) = \frac{X - X_{min.} + 40}{2}$$

Size 3

$$L4 (a/b) = \frac{X - X_{min.} + 50}{2}$$

For exterior clamping
 2 elements 4311-22X
 2 elements 4311-24X
 and 4 connecting bars
 L4 (a/b) are required,
 2 each of the connec-
 ting bars must always
 have the same length.

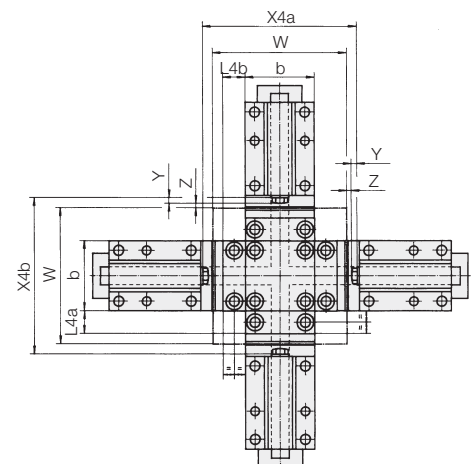

Hydr. element	right-hand	Part-no.	4311-221	4311-222	4311-223
Hydr. element	left-hand	Part-no.	4311-241	4311-242	4311-243
Mech. element	right-hand	Part-no.	4311-321	4311-322	4311-323
Mech. element	left-hand	Part-no.	4311-341	4311-342	4311-343
Crossing 3 elements		Part-no.	0432-300	0432-301	0432-302
Crossing 4 elements		Part-no.	0432-400	0432-401	0432-402

Please indicate dimension L or dimension X on your order or inquiry

Clamping possibilities

