

Parallel Slide Centering Element

double acting, max. operating pressure 500 bar

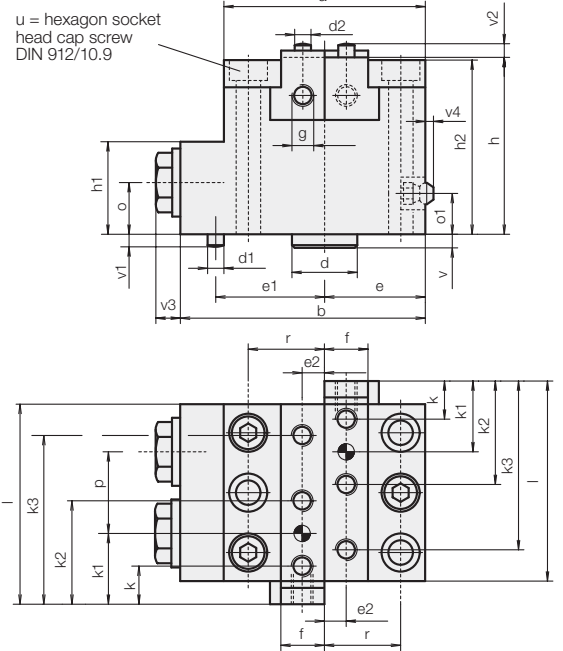
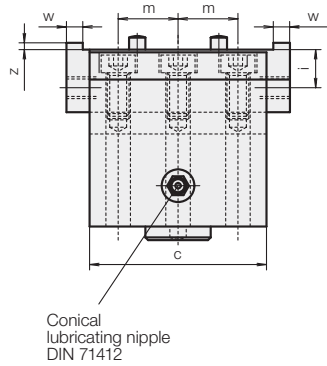

Application

This element is used in clamping systems in order to centre workpieces with small complicated contours and ribbing serving as a base for the definition of tolerances.

Description

By a clever arrangement of the centre of rotation to the hydraulic piston the retaining force of a clamping jaw is three times higher than the clamping force. If only one clamping jaw acts at the workpiece, the clamping force is twice as large. This happens as long as the workpiece is moved to the centre.

Advantage

- Thanks to the compact overall dimensions the element is suitable for installation in any hydraulic clamping system.

Clamping jaws

The clamping jaws, to be manufactured by the customer according to the special application, are precisely positioned at the clamping slide by means of a centre pin and a lateral key. The clamping jaws are fixed from above by means of 3 screws and from the side by 1 screw. The above figure shows a parallel slide centring element with clamping jaws and contact bolts. The clamping process is effected from the inside to the outside (interior clamping).

Representation of principle

Double-acting parallel slide centering element

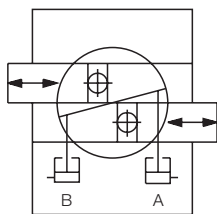

Position of clamping slides for interior and exterior clamping see page 2

Centering repeatability ± 0.02 mm

Clamping force/jaw FSp at y	[kN]	2.8	5.0	8.8
Stroke/jaw	[mm]	6	7	8
Piston \varnothing	[mm]	12	16	20
a	[mm]	62	74	90
b	[mm]	82	90	105
c	[mm]	55	65	75
d h6	[mm]	22	24	26
d1 m6	[mm]	6	8	8
d2 m6	[mm]	6	6	8
e	[mm]	31	37	45
e1 ± 0.02	[mm]	40	40	50
e2 ± 0.1	[mm]	7	9	11
f	[mm]	13	16	20
q	[mm]	M 6 x 10	M 8 x 11	M 10 x 13
h	[mm]	56	65	76
h1	[mm]	31	34	42
h2	[mm]	55	64	75
i	[mm]	12	14	17
k	[mm]	12	14	17
k1 ± 0.02	[mm]	22	26	31
k2	[mm]	32	38	45
k3	[mm]	52	62	73
l	[mm]	62.5	73.5	85
m	[mm]	20	22	27
o	[mm]	16	19	21
o1	[mm]	13	15	15
r	[mm]	23	28	34
u 3x	[mm]	M 6 x 60	M 8 x 70	M 10 x 80
v	[mm]	4	5	5
v1	[mm]	5	6	6
v2	[mm]	5	5	6
v3	[mm]	9	9	7
v4	[mm]	3	0	0
w j7	[mm]	5	6	8
z	[mm]	2.2	2.5	3
Weight	[kg]	1.7	2.7	4.4
Oil volume per mm clamping slide stroke	[cm ³]	0.16	0.28	0.47
Part-no.		4316-120	4316-160	4316-200

网址: www.fdzc.net 联系人: 程家雄 手机: 13601809714

联系电话: 021-51872743

E-mail: chengff@sh163.net

Exterior clamping

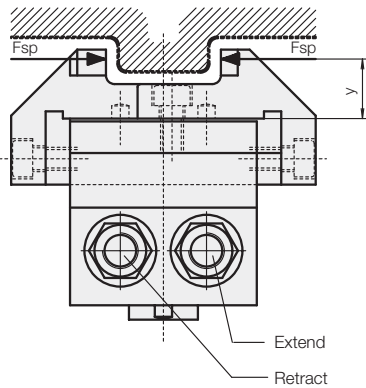

Interior clamping

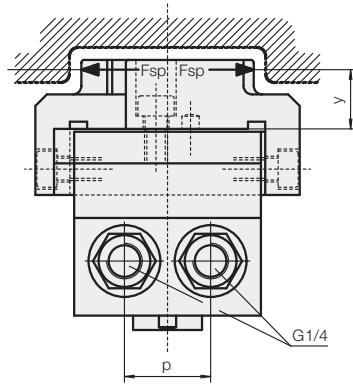

Example of clamping jaw (to be manufactured by the customer)

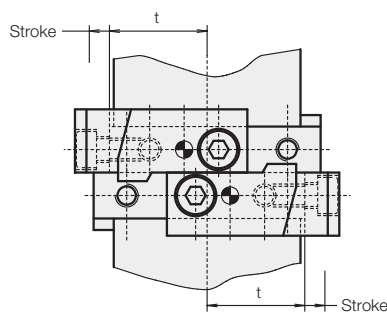
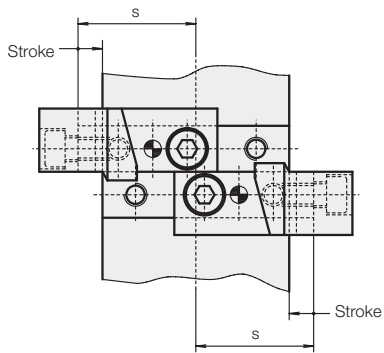
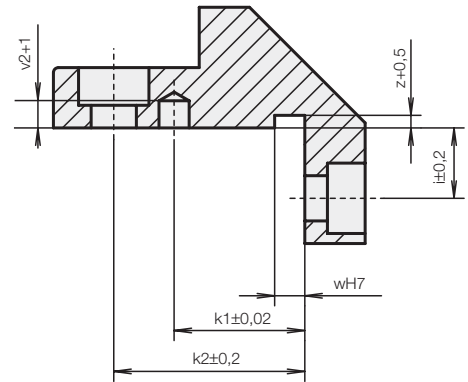

p	[mm]	26	30	37
s	[mm]	35	41	47,5
t	[mm]	29	34	39,5
y applic.of force	[mm]	20	24	28

Hint

In case of 2 x y the clamping force will be reduced by 6% (friction loss).

Application example

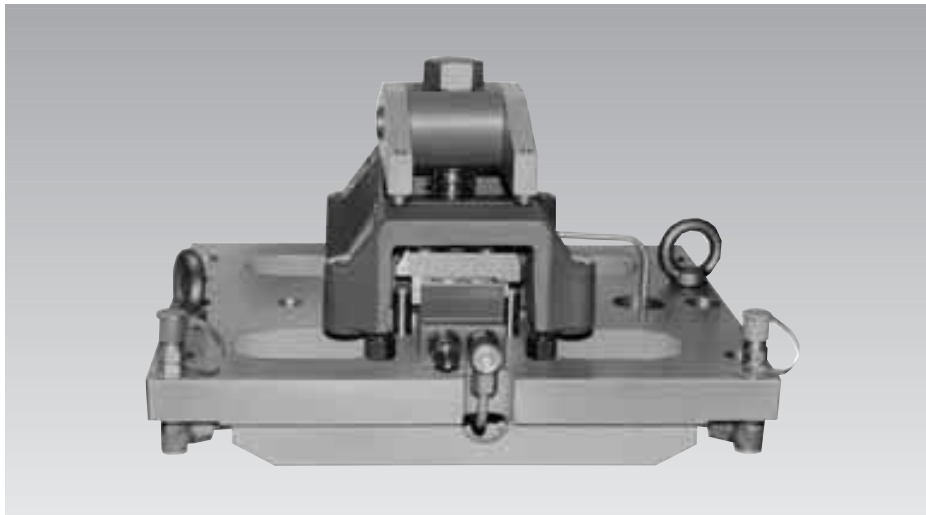

The opposite figure shows a hydraulically-operated fixture for concentric positioning and clamping of two casted housings, whose interior surfaces are due to functional reasons have to be concentrically arranged to the machined holes.

The machining of the interior surfaces could be avoided thanks to the use of concentric clamping elements.

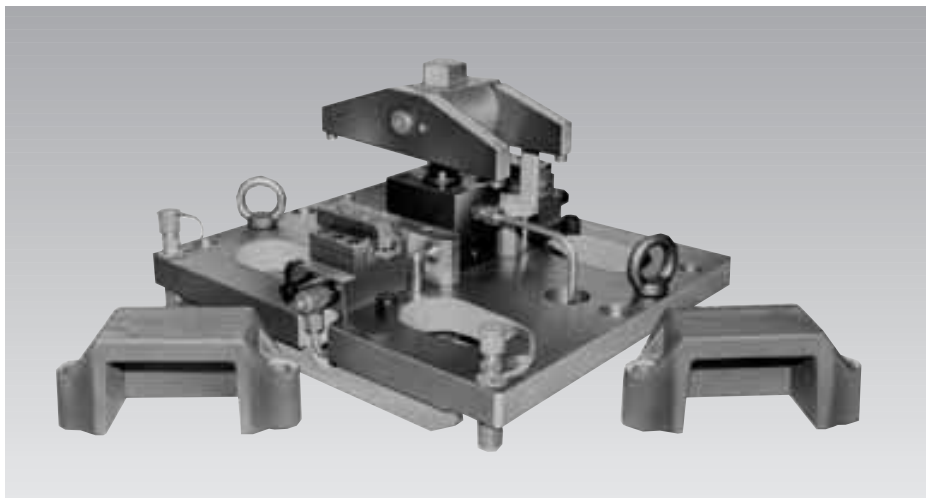

The clamping fixture in plate constructions installed on a vertical machining centre with rotary indexing table and trunnion bearing.