

## Fixture clamp, concentric clamping

max. clamping force 9.5 kN and 15 kN, jaw width 40 and 65 mm  
double acting, max. operating pressure 250 bar



### Advantages

- Very compact design
- High rigidity
- Repetitive accuracy  $\pm 0.02$  mm
- 2 sizes
- Strokes 5 and 8 mm
- Double-acting function
- Fixtures without tubes possible
- Exchangeable jaws
- Good swarf protection
- Port for central lubrication
- Mounting position: variable

### Function

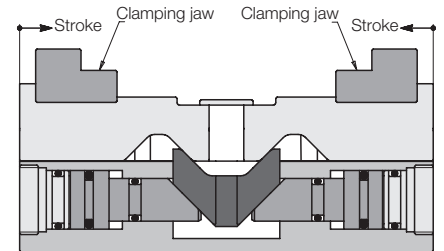

### Application

The fixture clamps are used for machining of dimensionally stable workpieces in single or multiple clamping fixtures. Due to their compact design they can be arranged in a very limited space. Fixture clamps are especially suitable for series manufacturing in automated mode. The double-acting cylinder function combined with central lubrication and good swarf protection guarantees a high process safety.

### Fixing from above

with accessory adaptor plate  
**Drilled channels**

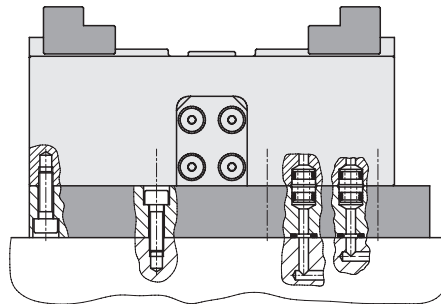

### Fixing from below

**Drilled channels**

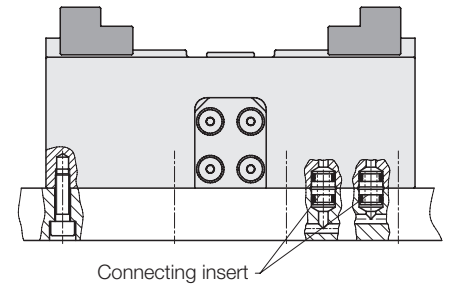

### Description

The fixture clamp with concentric clamping function consists of a very slim basic body with 2 integrated hydraulic cylinders. The piston forces are transferred via a guided connecting link to the two clamping slides so that a centric synchronism is obtained. All threads and ports are at the bottom to allow a space-saving arrangement of several clamping points in a very limited space. If fixing from below is not possible an adaptor plate for manifold mounting or tube connection is available. As accessory also blanks of clamping jaws are available for adaptation to the workpiece contour.

### Fitting connection

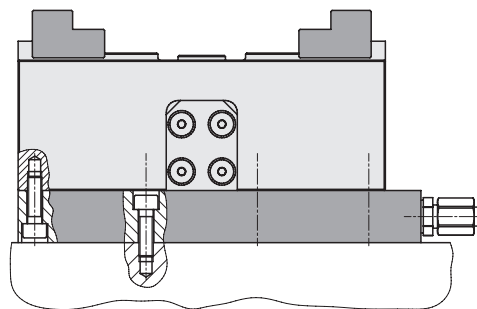

### Accessories

Clamping jaws and adaptor plate are not included in the delivery of the fixture clamp and have to be ordered separately as accessory.

### Important notes

The fixture clamp is only suitable for exterior clamping. Lubricate at the latest after 500 clamping cycles the clamping slide via the central lubrication. Never use the complete clamping stroke to guarantee safe clamping of the workpiece. Max. operating temperature 80 °C. Operating conditions and other data see data sheet A 0.100.

### Application example

Concentric clamping of 8 flanges on a rotary indexing fixture.

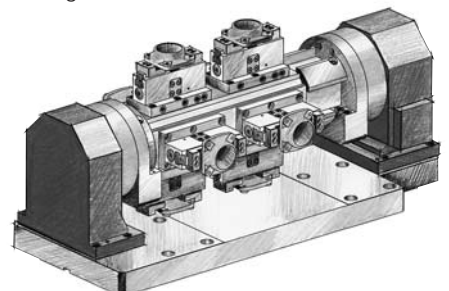

网址: [www.fdzc.net](http://www.fdzc.net) 联系人: 程家雄 手机: 13601809714

联系电话: 021-51872743

E-mail: [chengff@sh163.net](mailto:chengff@sh163.net)

Clamping stroke 5 mm  
**Technical data / Accessories**  
**Dimensions**

**Clamping stroke 5 mm: Part-no. 4413-050**

**Technical characteristics**

Clamping force max.	[kN]	9.5
Release force	[kN]	1
Min. operating pressure	[bar]	20
Clamping stroke	[mm]	5
Jaw width	[mm]	40
Max. flow rate	[cm <sup>3</sup> /s]	70
Stroke volume		
Clamping	[cm <sup>3</sup> ]	3.8
Unclamping	[cm <sup>3</sup> ]	2.2
Weight	[kg]	approx. 2.36

**Adaptor plate (accessory)**

Weight	[kg]	approx. 1.9
<b>Part-no.</b>		<b>0441-305</b>

**Clamping force diagram**

(Height of the clamping jaw 15 mm)

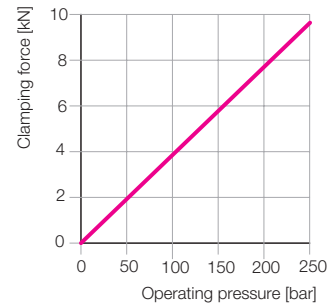

**Accessory: adaptor plate**

View from below

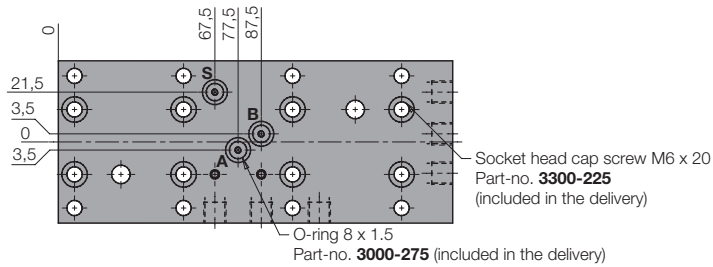

- A = Clamping  
 B = Unclamping  
 S = Central lubrication

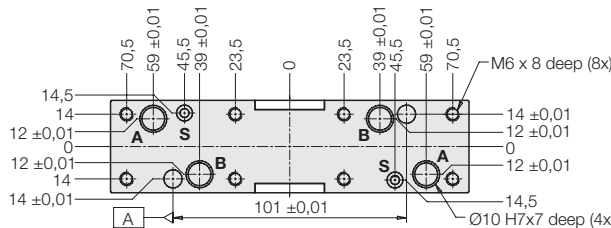

**Clamping and unclamping**

each Ø10 H7 x 7 deep for connecting insert **9210-132** (included in the delivery), see also page F 9.300

**Central lubrication**

2 x with O-ring **3001-842** (5x1 mm) (included in the delivery)

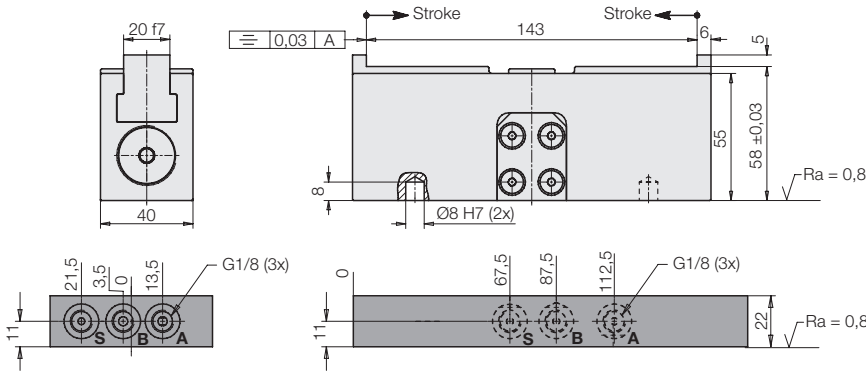

**Accessory: adaptor plate**

Side views

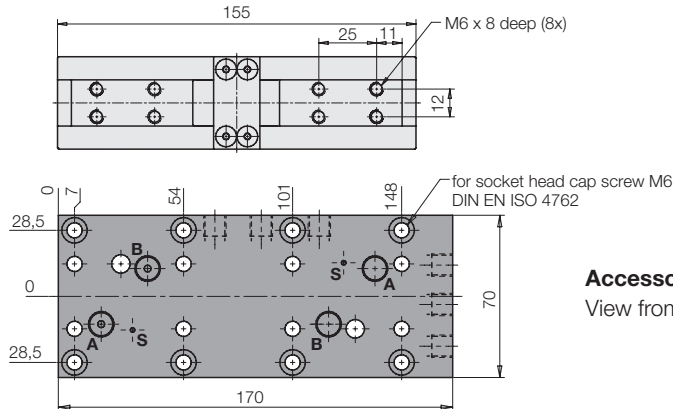

**Accessory: adaptor plate**

View from above

**Clamping stroke 8 mm: Part-no. 4413-150**

**Technical characteristics**

Clamping force max.	[kN]	15
Release force	[kN]	1
Min. operating pressure	[bar]	20
Clamping stroke	[mm]	8
Jaw width	[mm]	65
Max. flow rate	[cm <sup>3</sup> /s]	100
Stroke volume		
Clamping	[cm <sup>3</sup> ]	9,85
Unclamping	[cm <sup>3</sup> ]	4,4
Weight	[kg]	approx. 6

**Adaptor plate (accessory)**

Weight [kg] approx. 3,5  
 Part-no. **0441-315**

**Clamping force diagram**

(Height of the clamping jaw 25 mm)

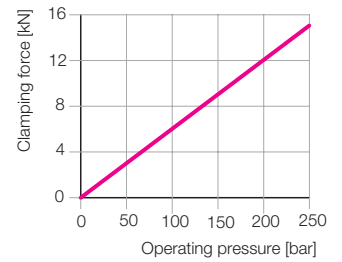

**Accessory: adaptor plate**

View from below

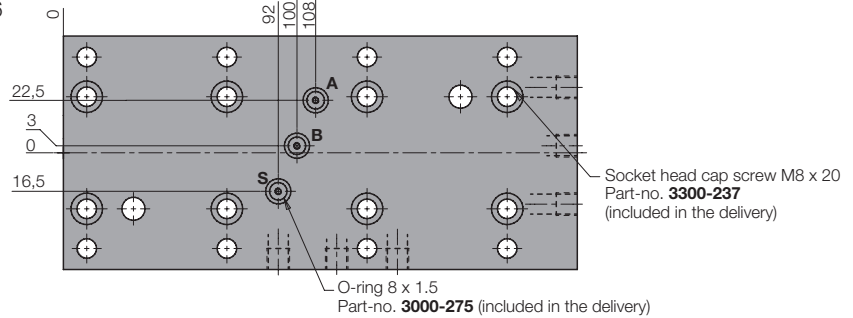

- A** = Clamping
- B** = Unclamping
- S** = Central lubrication

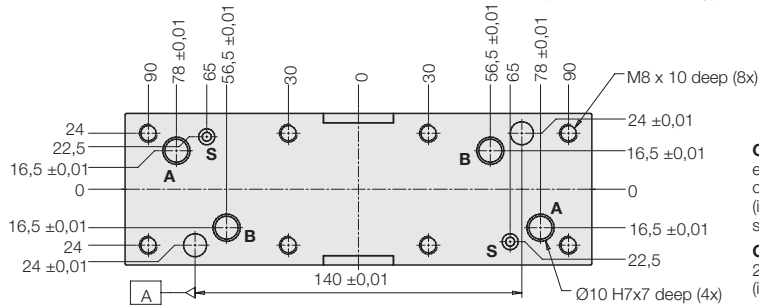

**Clamping and unclamping**  
 each Ø10 H7 x 7 deep for  
 connecting insert **9210-132**  
 (included in the delivery),  
 see also page F 9.300

**Central lubrication**  
 2 x with O-ring **3001-842** (5x1 mm)  
 (included in the delivery)

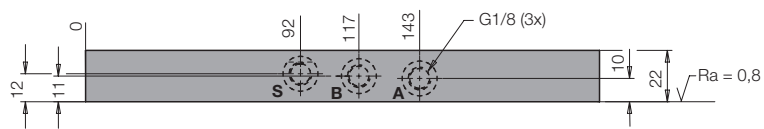
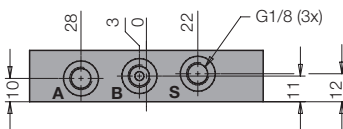
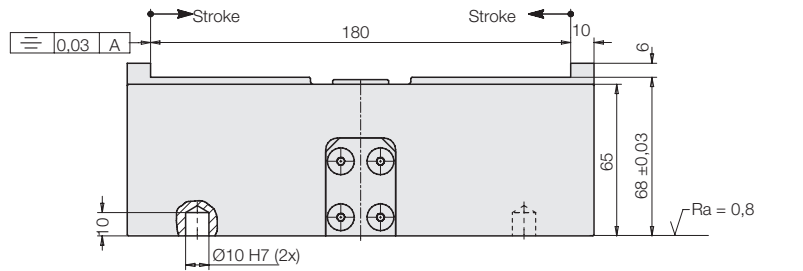
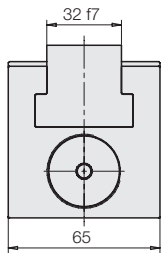

**Accessory:  
 adaptor plate**  
 Side views

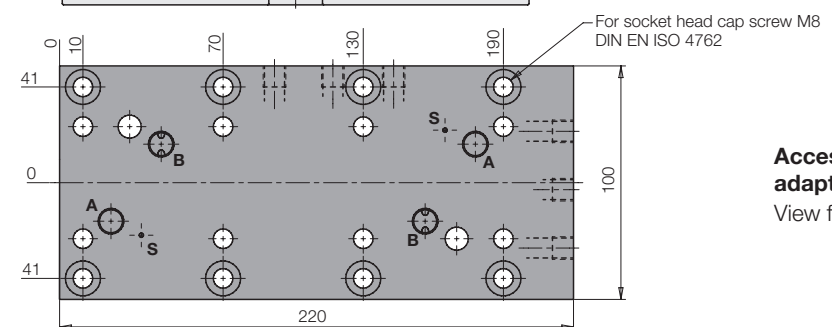
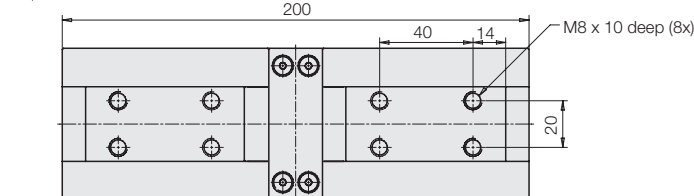

**Accessory  
 adaptor plate**  
 View from above

**For fixture clamp 4413-050**

**Clamping jaw blank 40 mm**  
**Part-no. 3548-070**

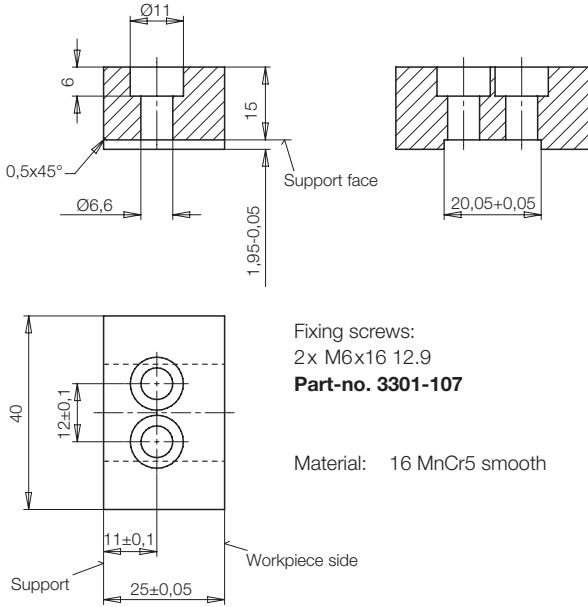

Fixing screws:  
 2x M6x16 12.9  
**Part-no. 3301-107**

Material: 16 MnCr5 smooth

**For fixture clamp 4413-150**

**Clamping jaw blank 65 mm**  
**Part-no. 3548-071**

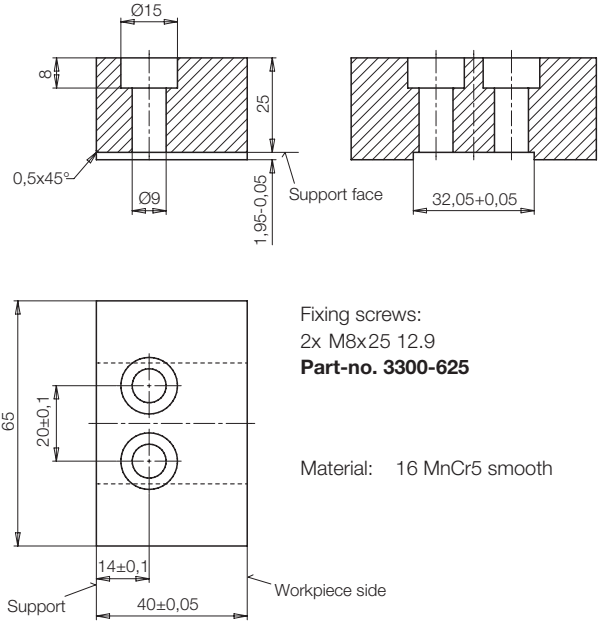

Fixing screws:  
 2x M8x25 12.9  
**Part-no. 3300-625**

Material: 16 MnCr5 smooth

**Self-made clamping jaws**

Clamping jaws are manufactured according to the contour of the workpiece to be clamped.

The max. height of the clamping jaw X at 250 bar operating pressure is indicated in the below charts.

If the operating pressure is lower, the clamping jaws can be designed higher as per the below diagrams.

**Important note**

The clamping jaws must always be supported by the provided support, since the fixing screws are not in the position to compensate the generated clamping forces.

**Max. height of the clamping jaws X for 4413-050 at max. operating pressure of 250 bar**

Fixing screws for clamping jaws	M6x16 - 12.9
X [mm] with 2 screws	15
X [mm] with 4 screws	36

**Fixing of the clamping jaws**

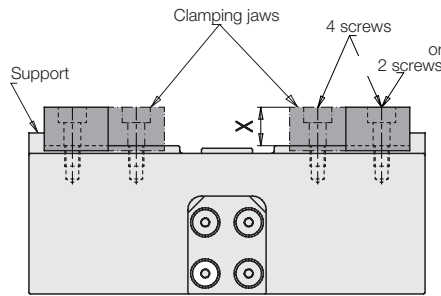

**Max. height of the clamping jaws X for 4413-150 at max. operating pressure of 250 bar**

Fixing screws for clamping jaws	M8x25 - 12.9
X [mm] with 2 screws	25
X [mm] with 4 screws	78

**Max. height of the clamping jaw X for 4413-050 as a function of the operating pressure**

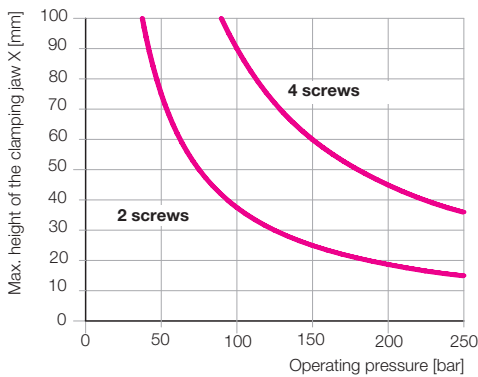

**Max. height of the clamping jaw X for 4413-150 as a function of the operating pressure**

