

## Press-In Devices 150 kN bench devices with electro-hydraulic control

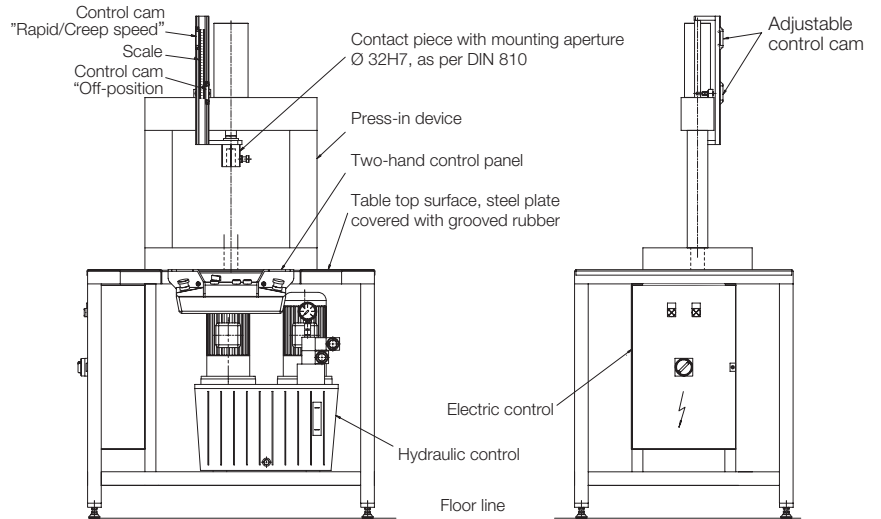
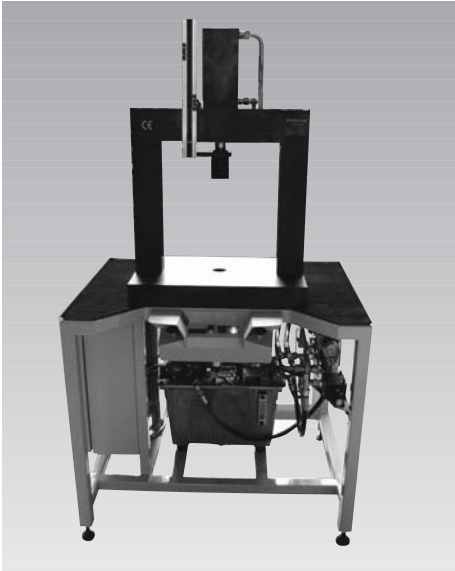

### Application

Press-in devices for assembly are preferably used in assembly processes for production of longitudinal pressed joints. In addition, the assembly conditions require frequently a rigid O-shaped press-in frame.

### Advantages

- High flexibility in assembly
- Improved ergonomics
- Quality assurance of operation
- Reduction of assembly time
- Short amortisation time
- Closed force-loop
- Defined force ratios
- Light component load
- Quick-change tooling system

### Industry/applications (selection)

- Drive technology, gears box assembly
- Couplings, cardan shafts
- Compressors, pumps, hydraulic elements
- Industrial fittings
- Materials-handling technology
- Automotive industry and their suppliers
- Machine tool building
- Building and agricultural machines
- Electronics

### Description

Press-in device as bench device is a complete functional unit and consists of 3 basic components: mechanical press-in device, electro-hydraulic control and underframe for tables. Above the table plate there are - according to the application of ergonomic design rules - the mechanical press-in device and at the table frame the two-hand safety control. The electric control box and the hydraulic power unit are installed in the lower table area. Due to safety reasons, operation of the hydraulic cylinder is always made by a two-hand safety control. The press-in device is equipped with a rapid and creep speed control and a return stroke limitation.

### Application and installation instructions

When installing the press-in device it has to be considered that it will be installed on a plain surface and will be carried by all 4 legs. According to the operating instructions the electric connection has to be effected and the hydraulic power unit must be filled with mineral oil.

### Functions

#### Automatic mode

By operating the mushroom push-buttons at the two-hand operating panel simultaneously, the hydraulic cylinder extends rapidly starting from the retracted off-position. When the 1st proximity switch "rapids/creep speed" is actuated, the control switches automatically during the motion to creep speed. When the maximum press-in pressure is obtained, reversing to retraction is automatically effected and the hydraulic cylinder retracts rapidly until the 2nd proximity switch "Off-position" is actuated. The switching points of the proximity switches are continuously adjustable. The lamps at the two-hand operating panel indicate if the off-position and the maximum press-in pressure are achieved. The automatic mode can only be started, if the hydraulic cylinder is in the retracted off-position.

#### Setting mode

In addition, the functions "Extend" and "Retract" can be separately selected by means of a selector switch at the two-hand operating panel. In the setting mode, the press-in device can only be operated in creep speed. The proximity switches are not in operation.

Function triggering is - in all operating conditions - only possible by operating simultaneously both mushroom push-buttons of the two-hand operating panel.

网址: [www.fdzc.net](http://www.fdzc.net) 联系人: 程家雄 手机: 13601809714

联系电话: 021-51872743

E-mail: [chengff@sh163.net](mailto:chengff@sh163.net)

## Press-in device 150 kN

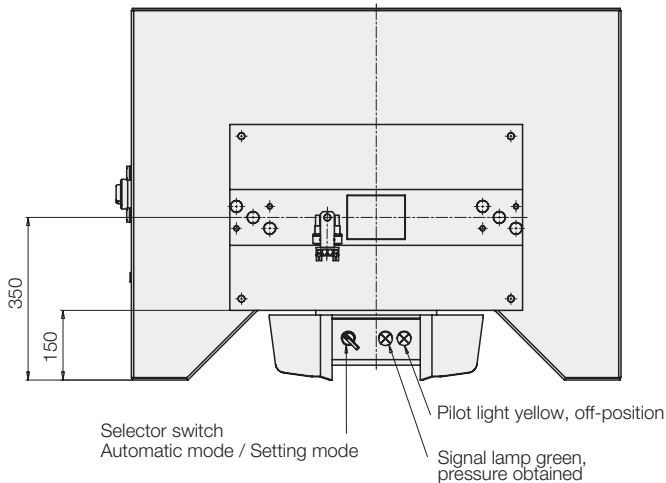
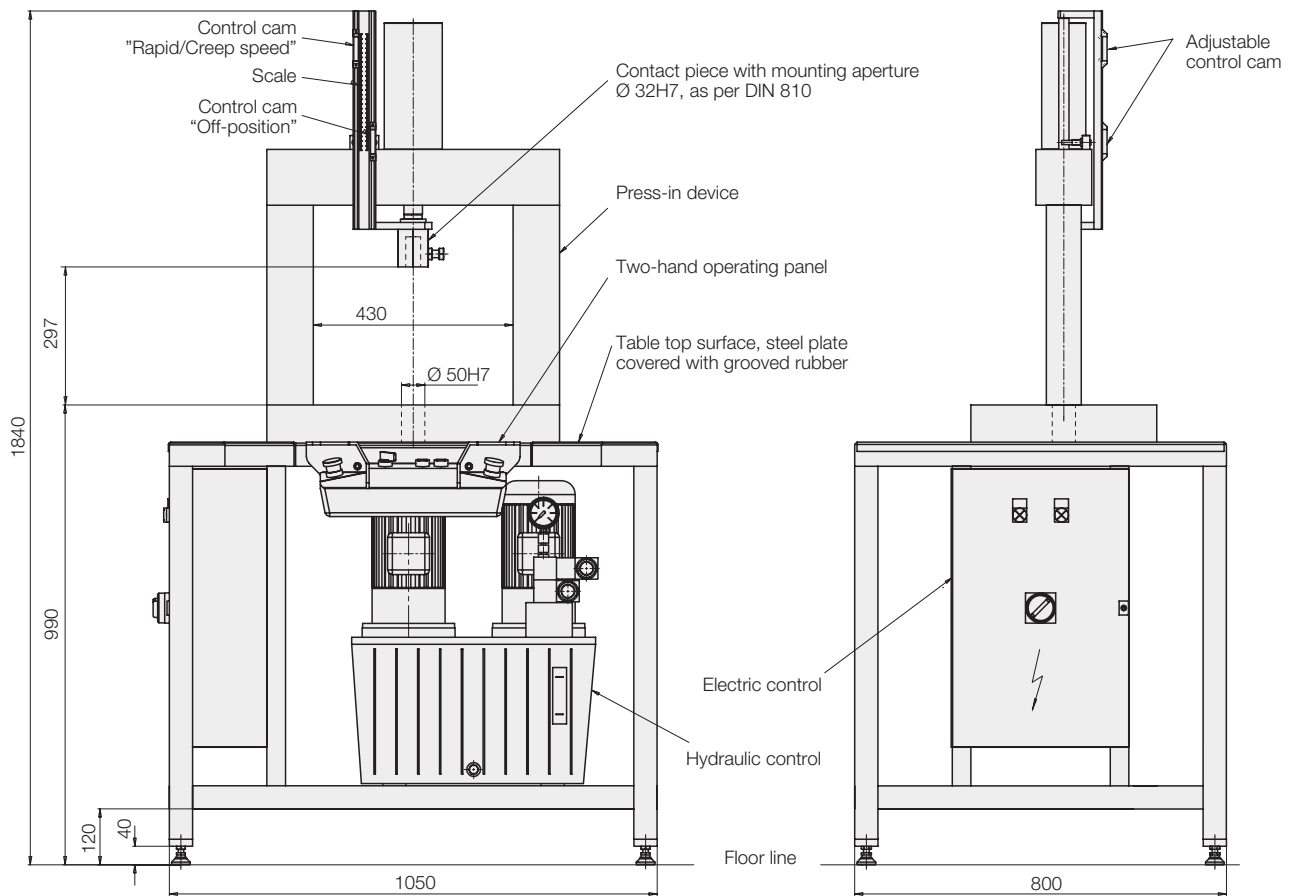

Nominal pressure force	[kN]	<b>150</b>
Cylinder stroke	[mm]	200
Flow rate	[l/min]	2.6 / 11.9
Max. operating pressure	[bar]	500 / 40
Oil volume	[l]	40
Rating	[kW]	2.2 / 1.1
Electric connection		3/PE (50 Hz 400 V)
Code class		IP 54
v- press-in stroke	[mm/s]	14
v- rapids extend	[mm/s]	78
v- rapids retract	[mm/s]	130
Weight	[kg]	440
<b>Part-no.</b>		<b>6600-500</b>

### Variants (selection)

- Base plate additionally equipped with diagonal slots as per DIN 650
- Table frame out of aluminium
- Press-in frame with additional protection cover
- Additional equipment for press-in force control

Special versions on request

网址: [www.fdzc.net](http://www.fdzc.net) 联系人: 程家雄 手机: 13601809714

联系电话: 021-51872743

E-mail: [chengff@sh163.net](mailto:chengff@sh163.net)