

## Assembly Tables

functions: lifting, swivelling, rotating, tilting  
workpiece weights up to 250/500/1000 kg



### Application

Assembly tables are used for assembly of heavy components and groups of components. The most favourable height and position for the corresponding assembly work can be adjusted.

Function sequence and control can be adapted to the assembly process by using different variants.

These tables can be retrofitted in a flexible way for other assembly tasks in a very short time and are also used for single workpieces.

Using these tables in assembly systems, installations can be realized where components are supplied to the workpiece place of a single operator. A completely assembled workpiece is obtained in one cycle.

Application of these tables is particularly suitable for assembly processes which require high forces e.g. clamping, pressing in or out.

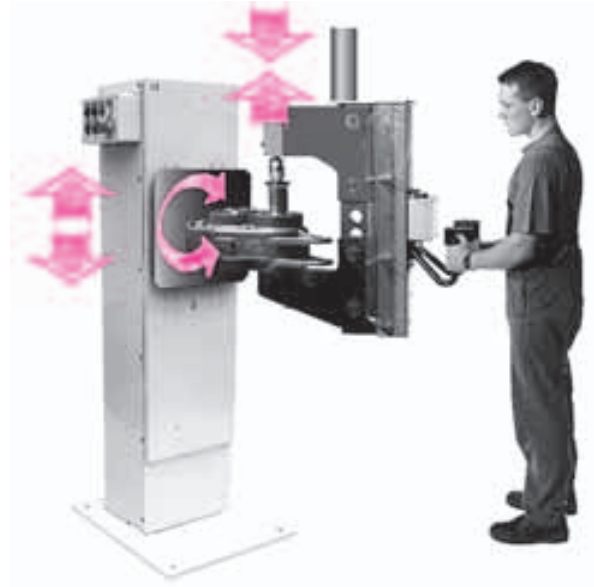

### Industry/applications (selection)

- ◆ Drive technology, gears box assembly
- ◆ Couplings, cardan shafts
- ◆ Compressors, pumps, hydraulic elements
- ◆ Industrial fittings
- ◆ Materials-handling technology
- ◆ Automotive industry and their suppliers
- ◆ Machine construction
- ◆ Building and agricultural machines
- ◆ Electronics

### Advantages

- improved ergonomics
- less expenditure of energy
- important assembly volume
- high flexibility
- shorter processing time
- small retrofitting expenditure
- lower fixture costs
- short clamping and positioning time

### Description

These assembly tables are stable welded structures with adjusting and fixing holes for fixing on the floor. A special foundation is not required. The guiding profiles are reinforced to compensate the tilting and turning moments.

The assembly tables correspond to the CE machine tool guide lines.

The realization of the electric control is made as per VDE, IEC and VBG 4. Actuation is made by electrical control elements with touch control.

### Application and installation instructions

When installing the assembly tables it has to be considered that they will be installed on a plain surface and fixed on the floor as per the operating instructions.



网址: [www.fdzc.net](http://www.fdzc.net) 联系人: 程家雄 手机: 13601809714

联系电话: 021-51872743

E-mail: [chengff@sh163.net](mailto:chengff@sh163.net)

# Technical characteristics

## Version Hv / Dv / HDv

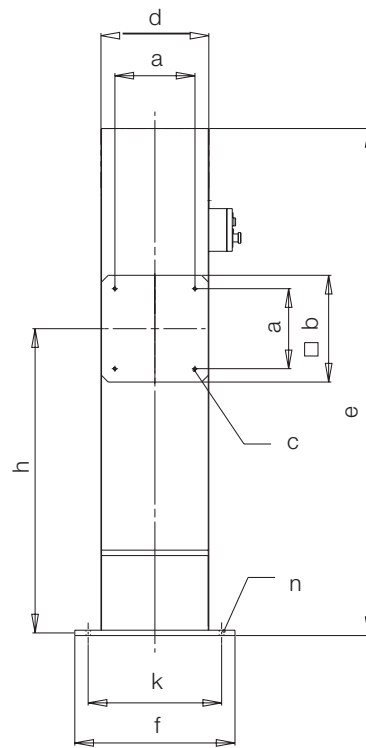
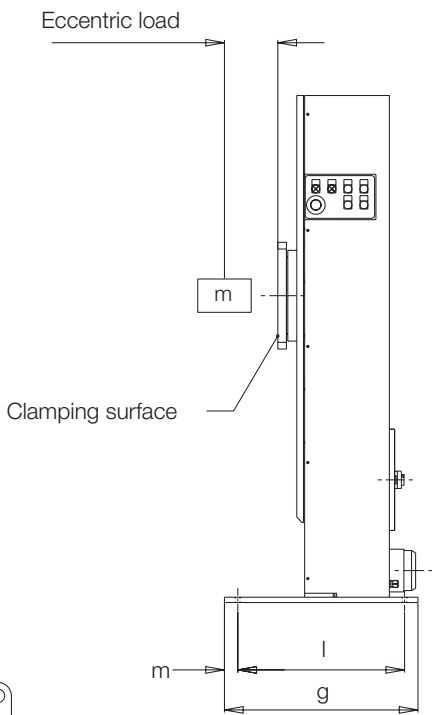
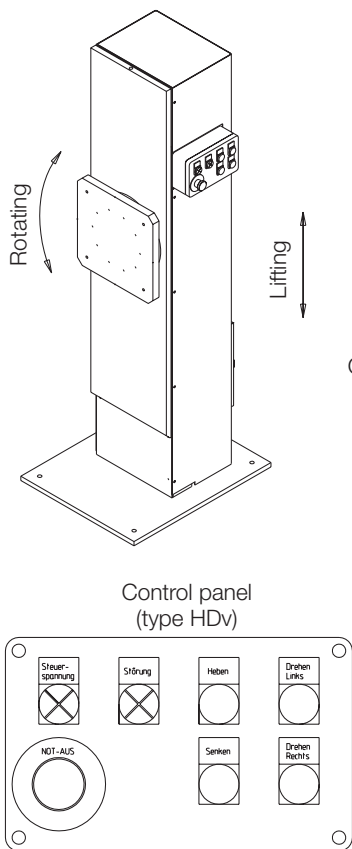

H = Lifting  
 D = Rotating  
 S = Tilting  
 v = vertical  
 h = horizontal

## Version with angle seat Hh / Sh / HSh

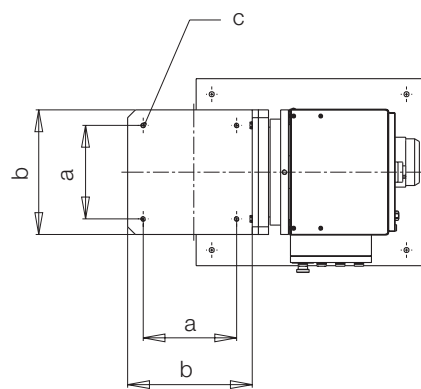
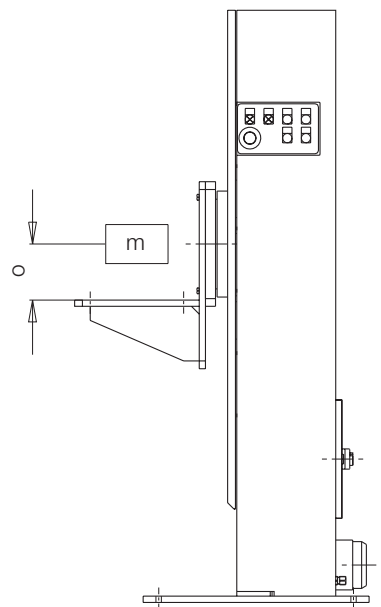

Version		Hv / Dv / HDv / Hh / Sh / HSh		
		250	500	1000
Load [m]	[kg]	250	500	1000
Eccentric load to clamping surface (max.)	[mm]	200	350	600
a	[mm]	300	500	700
b	[mm]	400	595	950
c	[mm]	4 x M 12	4 x M 20	4 x M 24
d	[mm]	404	600	950
e	[mm]	1900	2300	2400
f	[mm]	600	1000	1150
g	[mm]	725	1350	1550
h	[mm]	1150	1150	1150
k	[mm]	500	900	1050
l	[mm]	625	1250	1450
m	[mm]	50	50	50
n	[mm]	17	22	22
o	[mm]	200	300	475
Number of revolutions *	[U/min]	2.5	2.5	2.5
Torque *	[Nm]	320	1750	3500
Stop points *		4 x 90°	4 x 90°	4 x 90°
Height adjustment **	[mm]	±250	±250	±250
Lifting speed **	[mm/min]	2600	1500	1500
Power	[kW]	0.75/0.37/1.1	1.5/2.2/4	4/4/7.5
Weight	[kg]	610	1600	2600
<b>Part-no.</b>	<b>Hv</b>	<b>6510-025</b>	<b>6510-050</b>	<b>6510-100</b>
<b>Part-no.</b>	<b>Dv</b>	<b>6512-025</b>	<b>6512-050</b>	<b>6512-100</b>
<b>Part-no.</b>	<b>HDv</b>	<b>6511-025</b>	<b>6511-050</b>	<b>6511-100</b>
Weight	[kg]	680	1770	3000
<b>Part-no.</b>	<b>Hh</b>	<b>6517-025</b>	<b>6517-050</b>	<b>6517-100</b>
<b>Part-no.</b>	<b>Sh</b>	<b>6518-025</b>	<b>6518-050</b>	<b>6518-100</b>
<b>Part-no.</b>	<b>HSh</b>	<b>6519-025</b>	<b>6519-050</b>	<b>6519-100</b>

Rotating drive DS-transmission brake motor  
 Lifting drive DS-gear motor with self-locking spindle  
 Electric connection 3/ PE (50 Hz 400 V) \* not for type Hv, Hh  
 Code class IP 54 / colour RAL 7032 / CE conformity \*\* not for type Dv, Sh

# Technical characteristics

## Version DK / HDK

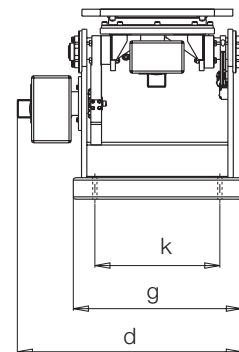
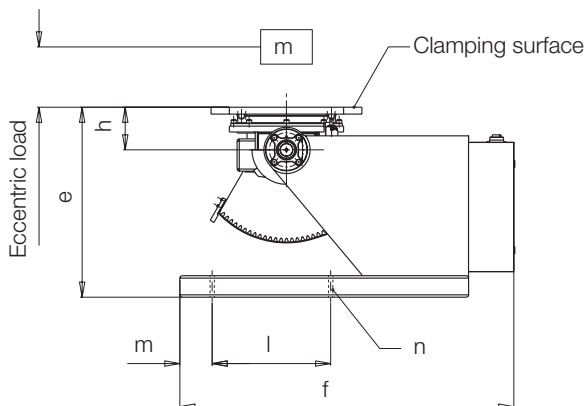
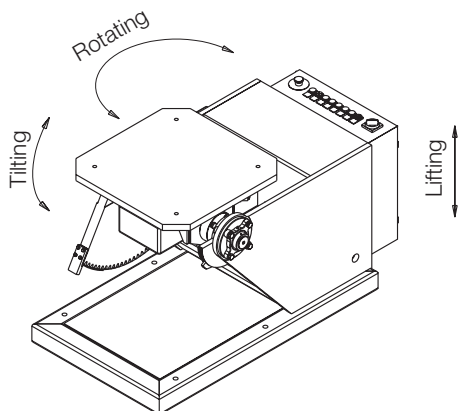

Control panel (type HDK)

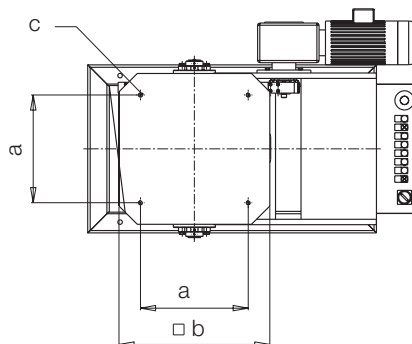
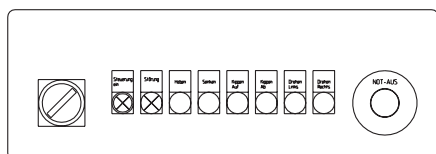

Version		DK/ HDK	DK/ HDK	DK/ HDK
		250	500	1000
Load [m]	[kg]	250	500	1000
Eccentric load to clamping surface (max.)	[mm]	200	425	600
a	[mm]	300	500	700
b	[mm]	400	700	950
c	[mm]	4 x M 16	4 x M 20	4 x M 24
d	[mm]	840	1040	1310
e	[mm]	882	882	882
f	[mm]	1350	1550	1750
g	[mm]	580	780	1050
h	[mm]	181	198	216
k	[mm]	480	680	930
l	[mm]	450	550	650
m	[mm]	150	150	150
n	[mm]	17	22	22
Number of revolutions	[U/min]	2.5	2.5	2.5
Torque	[Nm]	320	1750	3500
Stop points		4 x 90°	4 x 90°	4 x 90°
Tilting range		0 - 90°	0 - 90°	0 - 90°
Tilting time	[s]	10	10	10
Basic height	[mm]	882	882	882
Height adjustment ***	[mm]	±250	±250	±250
Lifting speed ***	[mm/min]	1500	1500	1500
Power	[kW]	2/4	3/5.5	4/7.5
Weight	[kg]	900	1850	2870

Part-no.	DK	6515-025	6515-050	6515-100
Part-no.	HDK	6516-025	6516-050	6516-100

Rotating drive	DS-transmission brake motor
Lifting drive	DS-gear motor with self-locking spindle
Tilting drive	DS-transmission brake motor with self-locking worm gear
Electric connection	3/ PE (50 Hz 400 V)
Code class	IP 54 / colour RAL 7032 / CE conformity

\*\*\* not for type DK

H = Lifting  
D = Rotating  
K = Tilting

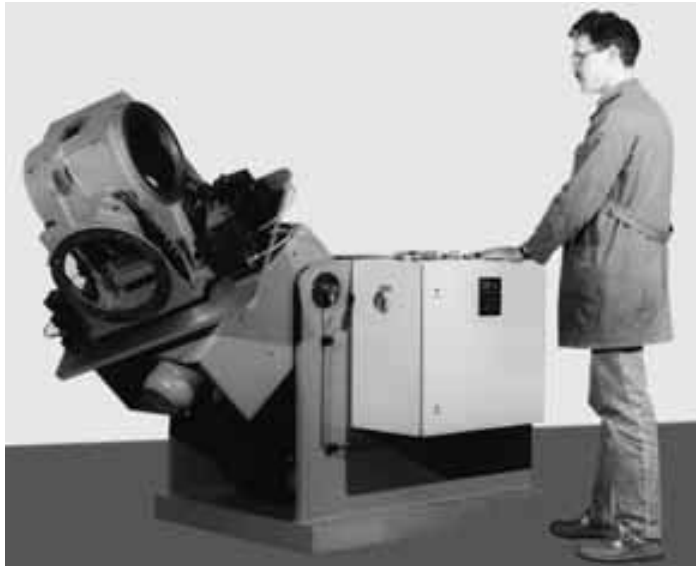

Application example for assembly of elevator gears  $m = 2000$  kg

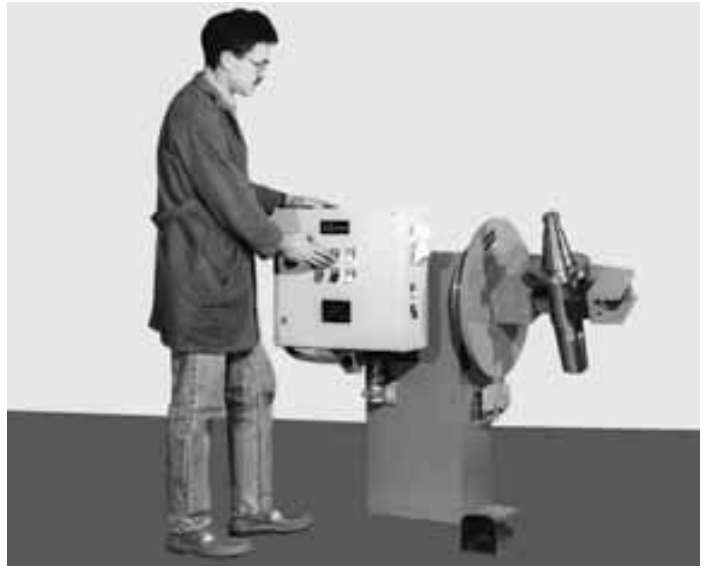

Assembly of subassemblies of worm wheel shafts for heavy gears



The figure shows a height-adjustable assembly table with rotating and tilting clamping surface in off-position



▲ Assembly table with rotating and tilting clamping surface

