

Swivel Element for Assembly Operations

Single lever operation – Indexing 90° *



Application

This swivel element was developed for assembly of devices, where assembly processes must be effected from different sides. It is required that the device to be mounted is placed in the most favourable position.

Description

Fixtures with one or two swivel axes can be made with this swivel element.

The installation position can be horizontally or vertically.

Swivelling and indexing is effected by means of a lever always to the same direction. When starting the swivel process the indexing bolt is automatically pulled out of the lock-in position, at the end of the swivel process it automatically snaps in again.

The swivel element can additionally be provided with a brake, which allows a locking of the fixture in each position.

4 fixing possibilities:

- vertical swivel axis figure ①
- horizontal swivel axis figure ②, ③, ④
to be turned by 90° each,
according to the desired position
of the swivel lever

Technical data

Weight of device at 200 mm distance of centre of gravity max. 50 kg
Max. dimension of device 300x300x300 mm

*Other indexes 60°, 45° and 30°

Discs can be exchanged

Indexing precision ±3'

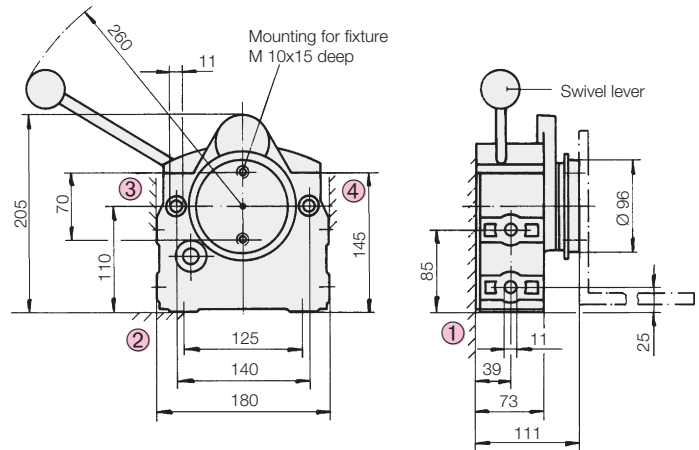

Swivel element

Part-no. 6505-101

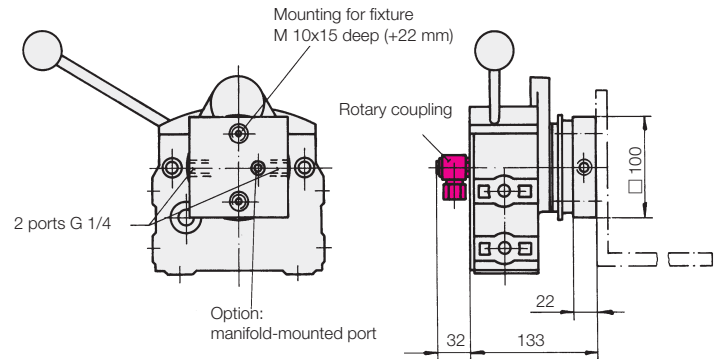

Swivel element with hydraulic rotary coupling
Swivel element with pneumatic rotary coupling

Part-no. 6505-111
Part-no. 6505-121

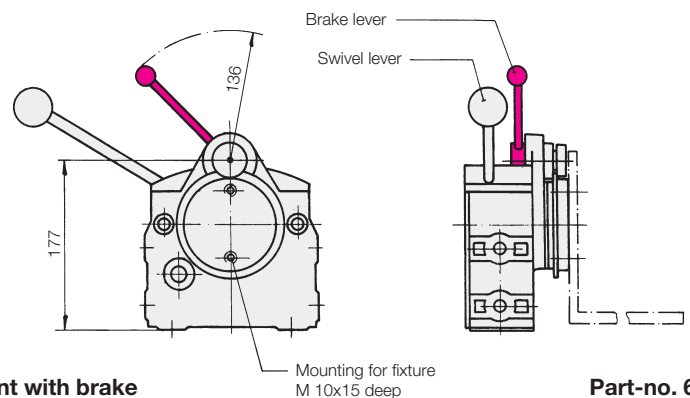

Swivel element with brake

Part-no. 6505-201

max. braking torque 100 Nm radially

Option: **with rotary coupling** as above

Part-no. 6505-211 or 221

Admissible force F in dependance with lever R in indexed mode and admissible weight in dependance with distance of centre of gravity

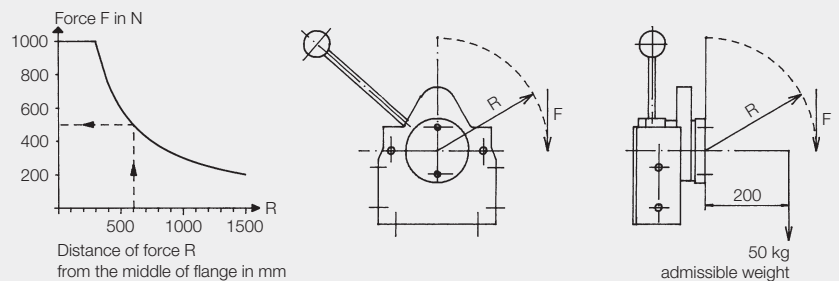

Application examples

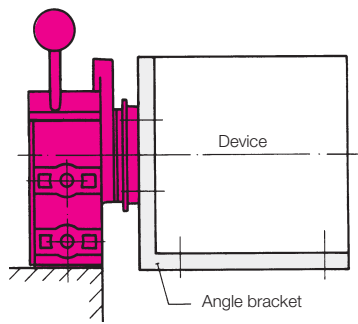

Swivel element with angle bracket

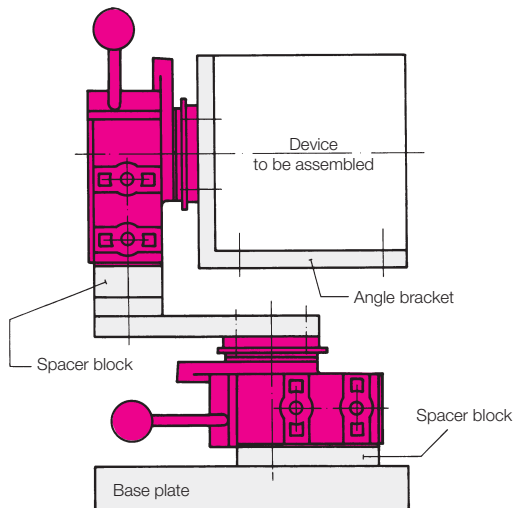

Swivel element with horizontal and vertical swivel axis (available on request)

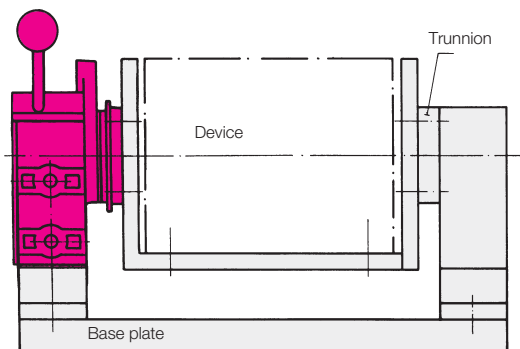

Swivel element with support (available on request)



The above fixture consists of swivel element, spacer block, angle bracket and base plate.

Swivel element for assembly operations with hydraulic lifting units as per data sheet M 6.910 for assembly in optimum working position



Swivelling, rotating, lifting, lowering



Swivel swivel element and extend lifting unit by foot operation



Assembly in optimum height and position