

## Working Table with electrically-operated height adjustment



### Advantages

- Good accessibility
- High flexibility
- Improved productivity
- Optimised ergonomics
- Simple operation
- Short amortisation time

### Application

Working tables with height adjustment are indicated if manual works have to be effected. The users can individually adjust their optimum ergonomic working height. They are used in production plants of the industry.

### Operation

The optimum working position for the respective operator is obtained by operating the push-button of the electric lifting unit. The lifting motion is generated by a lifting unit with a spindle lifting gear. After release of the push-button, the motion will be immediately stopped.

### Material

The base consists of a lacquered steel construction. The lifting unit is made of anodized aluminium. The working plate consists of dimensionally stable Multiplex beech.

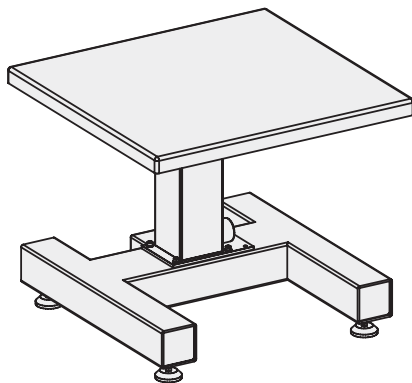
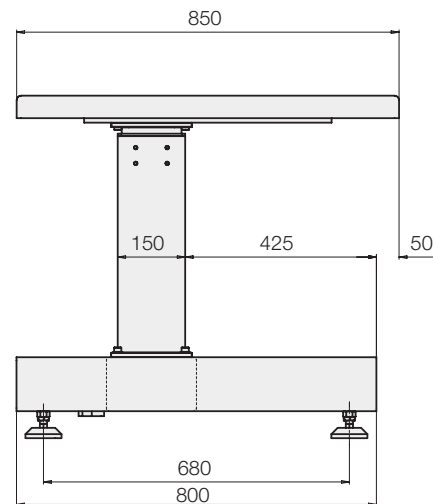
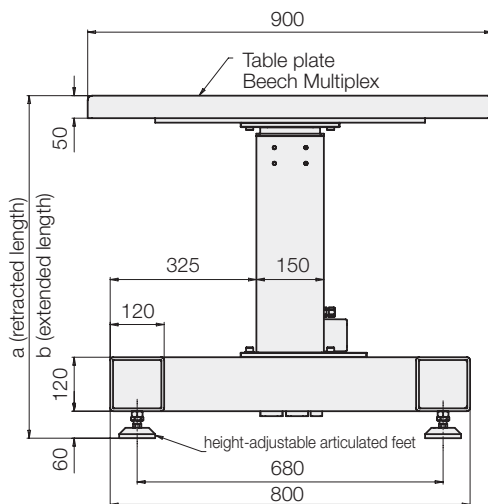

### Technical characteristics

Part-no.	Stroke [mm]	a [mm]	b [mm]
8917-220	200	660	860
8917-230	300	760	1060
8917-240	400	860	1260

### Application and installation instructions

The base is equipped with height-adjustable articulated feet. After installing the articulated feet supporting on all sides are screwed onto the floor and locked. The floor must be clean and flat. Protruding loads have to be avoided.

网址: [www.fdzc.net](http://www.fdzc.net) 联系人: 程家雄 手机: 13601809714

联系电话: 021-51872743

E-mail: [chengff@sh163.net](mailto:chengff@sh163.net)