

HSC 油壓轉角缸

Hydraulic Swing Clamp Cylinder

• Bore:ø25-ø63mm • Pmax:100kg/cm²

產品簡介

- 本產品適用於量產零件之專用機及MC治具，提高生產效率最佳幫手。
- 主要功能為油壓缸作動時，活塞下壓行程中壓板會旋轉到設計的角度，再沿著直線繼續下壓直到壓板夾緊工件。
- 建議使用油壓轉角缸，請加裝流量控制閥，避免速度過快，以及轉角行程中，請勿夾持工件，避免損壞缸體及內部零件。
- 壓板需增加長度時，請勿大於原長之1.5倍。
- 缸體材質採用機械構造用炭素鋼，內壁特殊加工處理，表面光滑，使用壽命長。

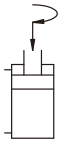

Product Introduction

- The product is ideal for mass production on a special purpose machine and jig on machining center. It will greatly upgrade production efficiency.
- When the hydraulic cylinder actuate, and the piston moves downward, the clamping arm will swing to a rated angle. Then it lowers until the workpiece is clamped securely.
- To avoid too fast motion a flow control valve is suggested to connect to the hydraulic swing clamp cylinder. Do not clamp workpiece while the calmp is swinging to avoid damaging on the cylinder barrel and internal parts.
- When increasing length of clamping arm is required, be sure do not exceed 1.5 times of the original length.
- The cylinder body is manufactured from structural carbon steel. Surface is specially treated for maximum smoothness on inside surface and long service life.



特性資料 Specifications

油缸內徑	Bore of cylinder	mm	ø25	ø32	ø40	ø50	ø63
活塞桿徑	Piston rod diameter	mm	ø18	ø20	ø22.4	ø28	ø35
轉角行程	Swing stroke	mm	9	11	11	13	13
垂直行程 標準/加長	Clamping stroke std/Incr	mm	13	15 / 30	15 / 30	17 / 34	17 / 34
受壓面積 拉入/推出	Pressure area pull/push	cm ²	2.37 / 4.91	4.9 / 8.04	8.63 / 12.57	13.47 / 19.63	21.55 / 31.17
理論夾持力	Theoretical clamping	30kg/cm ²	71	147	259	404	647
使用流體	Fluid	已濾清之標準液壓油 Filtered hydraulic oil					
最大操作壓力	Max operation pressure	100Kg/cm ²					
操作壓力範圍	Operation pressure range	5-70Kg/cm ²					
轉角方向	Rotating direction	R: 順時針右轉/ L: 逆時針左轉/ N: 0° 不旋轉 R: Turn right/ L: Turn left/ N: 0° No swing					
轉角角度	Rotating angle	標準角度90° 選擇角度45°, 60° Standard angle 90°, Optional angle 45°, 60°					
作動方式	Acting type	複動式 Double acting					

訂購標示法 Ordering Code

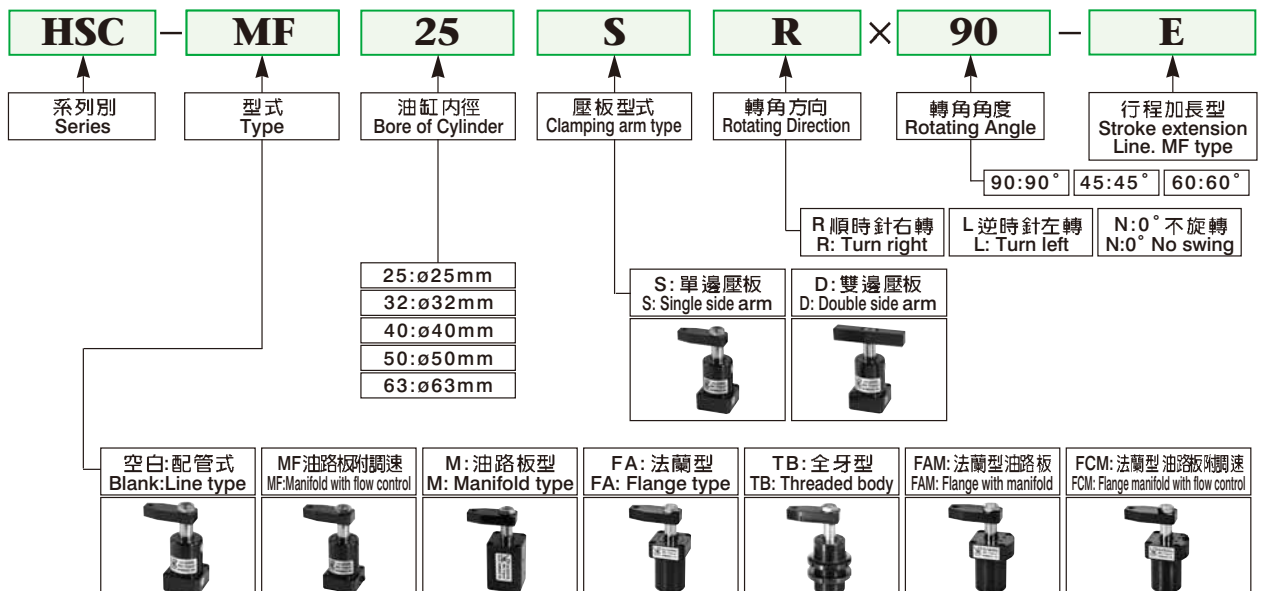

網址: www.fdzc.net 联系人: 程家雄 手机: 13601809714

联系电话: 021-51872743

E-mail: chengff@sh163.net

HSC 油壓轉角缸

Hydraulic Swing Clamp Cylinder

• Bore: $\phi 25$ - $\phi 63$ mm • Pmax: 100kg/cm²

單邊壓板旋轉示意圖

Single Side Swing Clamp

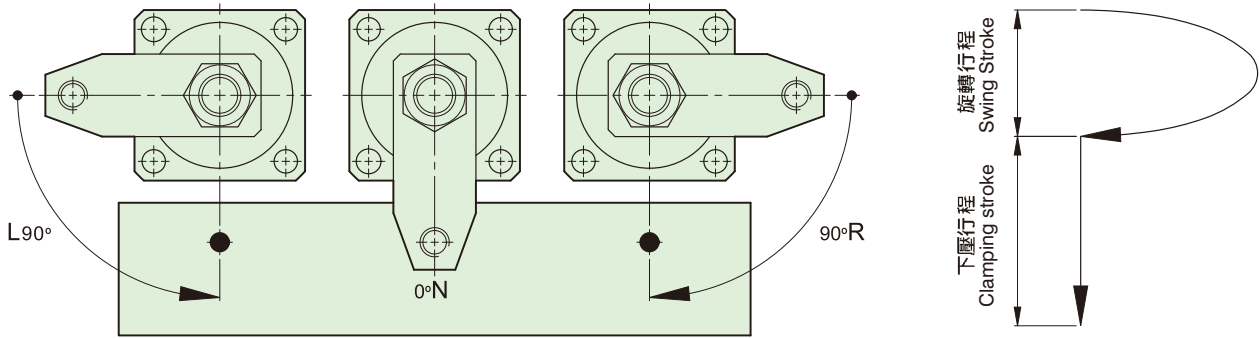

雙邊壓板旋轉示意圖

Double Side Swing Clamp

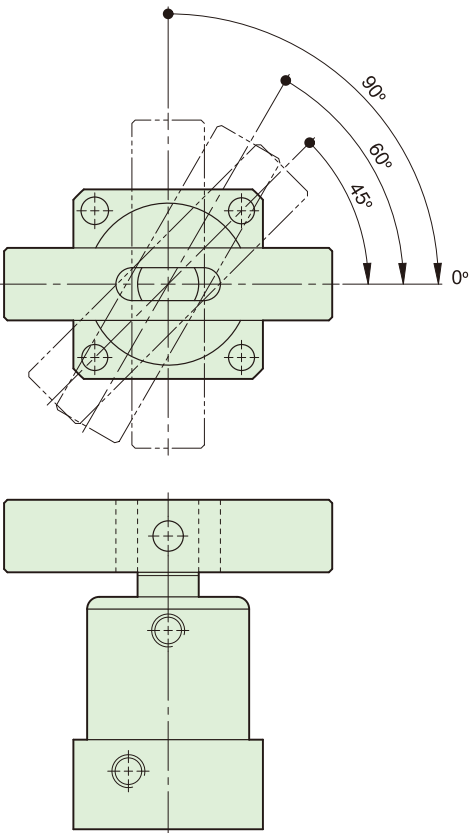

壓板鎖緊操作方式

Clamping Arm Mounting Methods

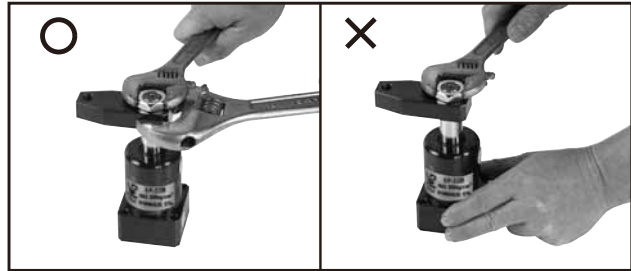

壓板拆卸操作方式

Clamping Arm Removing Methods



HSC 油壓轉角缸 Line type

Hydraulic Swing Clamp Cylinder

• Bore: $\phi 25$ - $\phi 63$ mm • Pmax: 100kg/cm²

HSC
B1-03

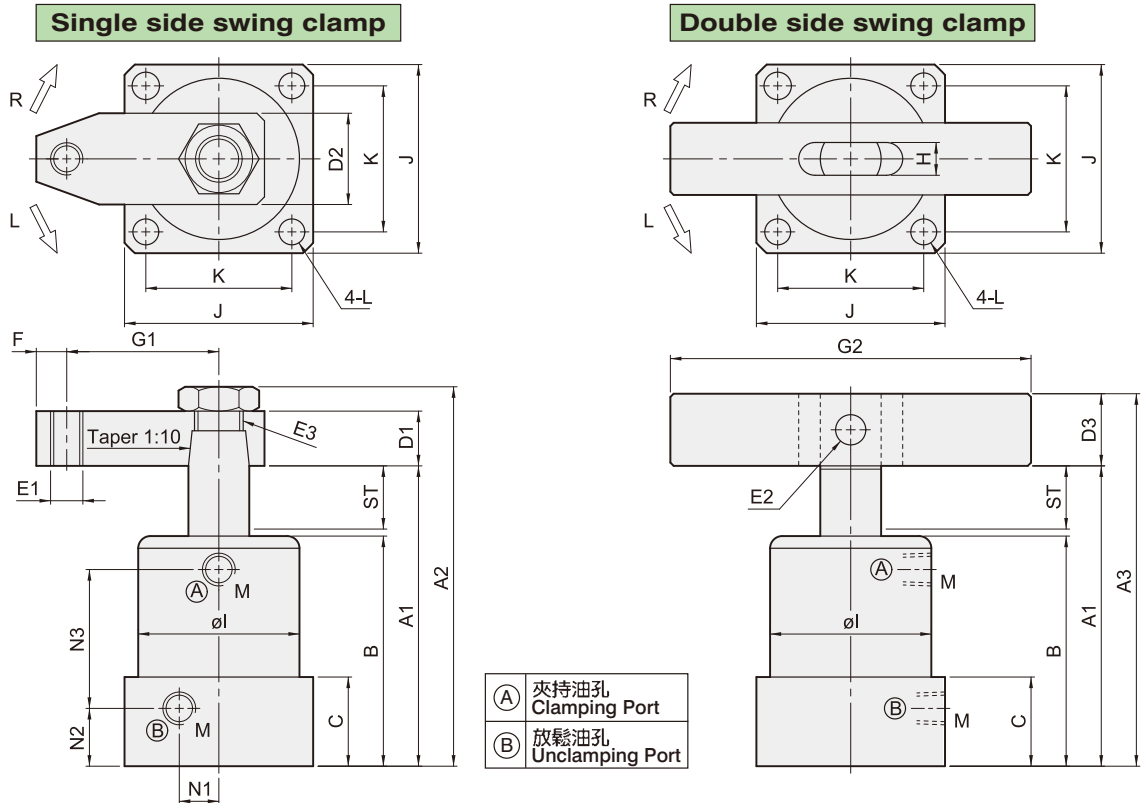

Dimensional table

UNIT:mm

ITEM \ MODEL	HSC-25	HSC-32		HSC-40		HSC-50		HSC-63	
ST: Swing/Clamping	22:9/13	26:11/15	41:11/30	26:11/15	41:11/30	30:13/17	47:13/34	30:13/17	47:13/34
A1	101	115	145	120	150	134	168	139	173
A2	(124)	(140)	(170)	(148)	(178)	(166)	(200)	(175)	(209)
A3	120	137.2	167.2	142.2	172.2	159.4	193.4	170.8	204.8
B	76	85	100	90	105	100	117	105	122
C	27	30		30		34		34	
D1	15	17		18		20		23	
D2	27	31		31		37		48	
D3	□19	□22.2		□22.2		□25.4		□31.8	
E1	M10x1.5	M10 x 1.5		M10 x 1.5		M12 x 1.75		M16 x 2.0	
E2	∅8	∅8		∅10		∅12		∅15	
E3	M14 x1.5	M16 x 1.5		M18 x 1.5		M20 x 1.5		M26 x 1.5	
F	10	10		10		12		15	
G1	50	55		60		65		75	
G2	140	160		160		180		200	
H	9	10		10		12		15	
∅l	∅46	∅50		∅54		∅66		∅80	
J	52	56		63		72		88	
K	40	44		48		57		70	
L	∅6.8	∅6.8		∅9		∅9		∅11	
M	PT1/8	PT1/8		PT1/8		PT1/4		PT1/4	
N1	8	10		12		15		17	
N2	17	19		19		21.5		22	
N3	46	52	67	57	72	63.5	80.5	68	85

网址: www.fdzc.net 联系人: 程家雄 手机: 13601809714

联系电话: 021-51872743

E-mail: chengff@sh163.net

HSC 油壓轉角缸 MF 油路板附調速

Manifold with flow control

Hydraulic Swing Clamp Cylinder MF

• Bore: $\phi 25$ - $\phi 63$ mm • Pmax: 100kg/cm²

HSC
B1-04

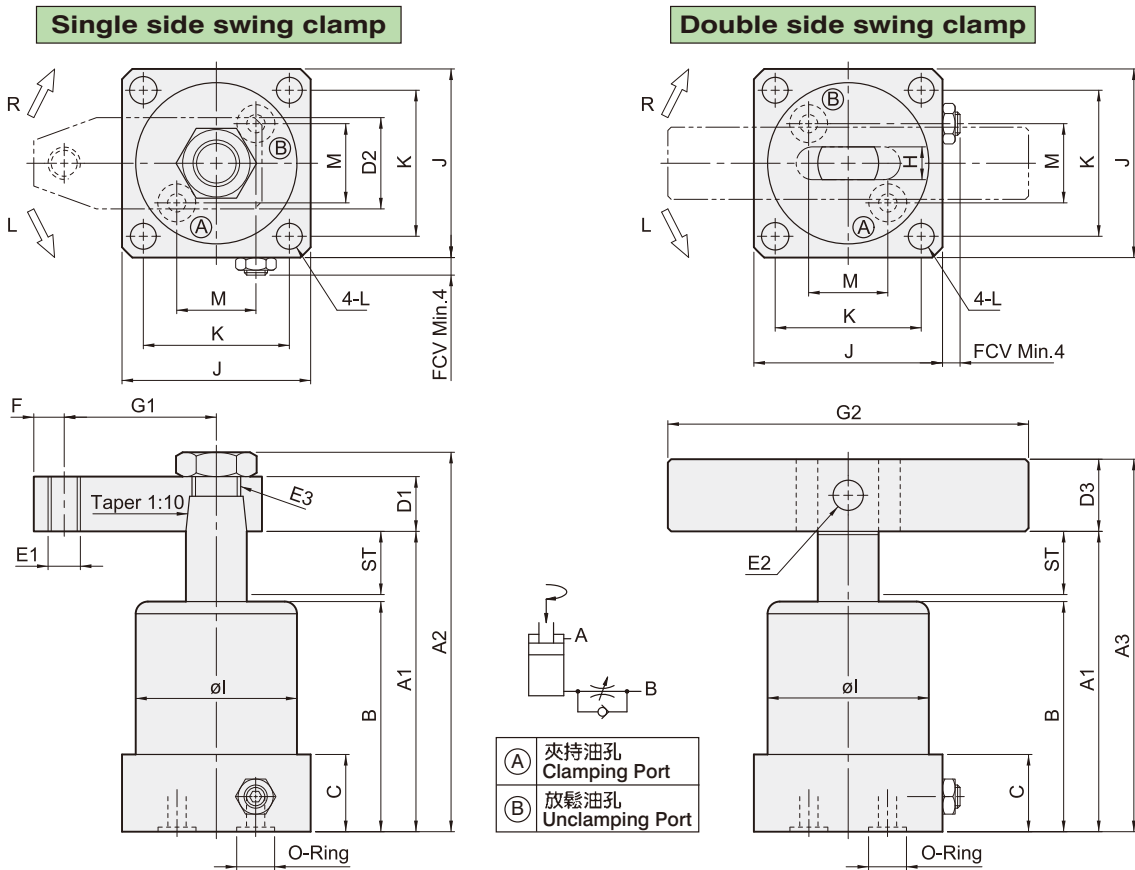

Dimensional table

UNIT:mm

ITEM \ MODEL	HSC-MF25	HSC-MF32	HSC-MF40	HSC-MF50	HSC-MF63
ST:Swing/Clamping	22:9/13	26:11/15 41:11/30	26:11/15 41:11/30	30:13/17 47:13/34	30:13/17 47:13/34
A1	101	115 145	120 150	134 168	139 173
A2	(124)	(140) (170)	(148) (178)	(166) (200)	(175) (209)
A3	120	137.2 167.2	142.2 172.2	159.4 193.4	170.8 204.8
B	76	85 100	90 105	100 117	105 122
C	22	25	25	30	30
D1	15	17	18	20	23
D2	27	31	31	37	48
D3	□19	□22.2	□22.2	□25.4	□31.8
E1	M10 x 1.5	M10 x 1.5	M10 x 1.5	M12 x 1.75	M16 x 2.0
E2	$\phi 8$	$\phi 8$	$\phi 10$	$\phi 12$	$\phi 15$
E3	M14 x 1.5	M16 x 1.5	M18 x 1.5	M20 x 1.5	M26 x 1.5
F	10	10	10	12	15
G1	50	55	60	65	75
G2	140	160	160	180	200
H	9	10	10	12	15
ϕl	$\phi 46$	$\phi 50$	$\phi 54$	$\phi 66$	$\phi 80$
J	55	57	63	72	88
K	42	44	48	57	70
L	$\phi 6.8$	$\phi 6.8$	$\phi 9$	$\phi 9$	$\phi 11$
M	19	21	23	28	32
O-Ring	P7	P7	P9	P9	P9

网址: www.fdzc.net 联系人: 程家雄 手机: 13601809714

联系电话: 021-51872743

E-mail: chengff@sh163.net

HSC 油壓轉角缸 M油路板型

Manifold type

Hydraulic Swing Clamp Cylinder

• Bore: $\phi 25$ - $\phi 50$ mm • Pmax: 100kg/cm²

Single side swing clamp

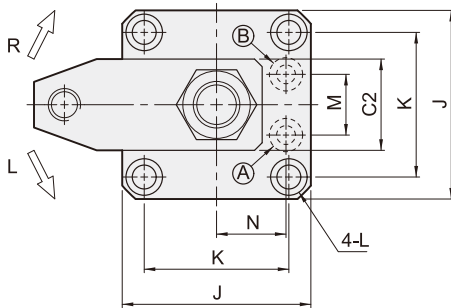

Double side swing clamp

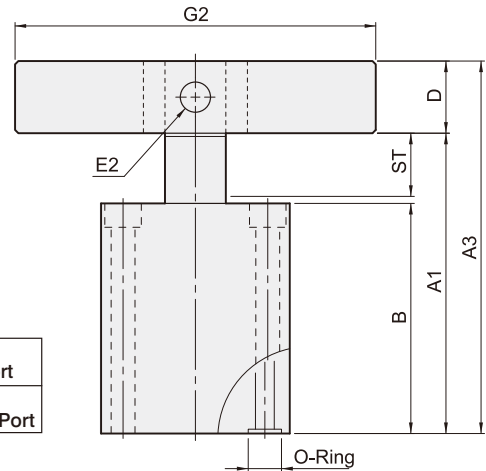
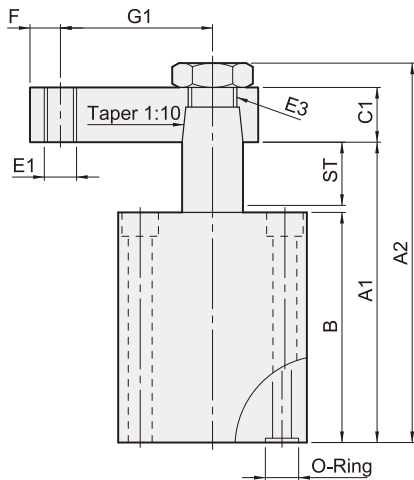
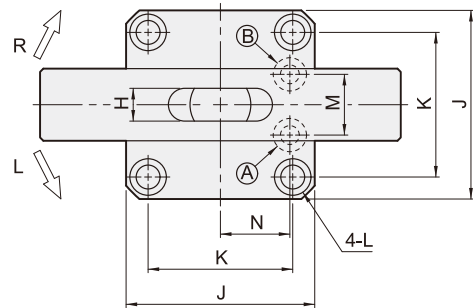

- (A) 夾持油孔
Clamping Port
- (B) 放鬆油孔
Unclamping Port

Dimensional table

UNIT:mm

ITEM \ MODEL	HSC-M25	HSC-M32	HSC-M40	HSC-M50
ST:Swing/Clamping	22:9/13	26:11/15	26:11/15	30:13/17
A1	101	115	120	134
A2	(124)	(140)	(148)	(166)
A3	120	137.2	142.2	159.4
B	76	85	90	100
C1	15	17	18	20
C2	27	31	31	37
D	□19	□22.2	□22.2	□25.4
E1	M10x1.5	M10x1.5	M10x1.5	M12x1.75
E2	$\phi 8$	$\phi 8$	$\phi 10$	$\phi 12$
E3	M14 x 1.5	M16 x 1.5	M18 x 1.5	M20 x 1.5
F	10	10	10	12
G1	50	55	60	65
G2	140	160	160	180
H	9	10	10	12
J	55	57	69	75
K	42	44	52	58
L	$\phi 6.8$ - $\phi 10.5$ x 6.5D.	$\phi 6.8$ - $\phi 10.5$ x 6.5D.	$\phi 9$ - $\phi 14$ x 9D.	$\phi 9$ - $\phi 14$ x 9D.
M	18	22	26	32
N	20	22	26	30
O-Ring	P7	P7	P8	P8

网址: www.fdzc.net 联系人: 程家雄 手机: 13601809714

联系电话: 021-51872743

E-mail: chengff@sh163.net

HSC 油壓轉角缸 FA法蘭型/TB全牙型 Flange type / Threaded body

Hydraulic Swing Clamp Cylinder FA.TB

• Bore: $\phi 25\text{-}\phi 63\text{mm}$ • Pmax: 100kg/cm^2

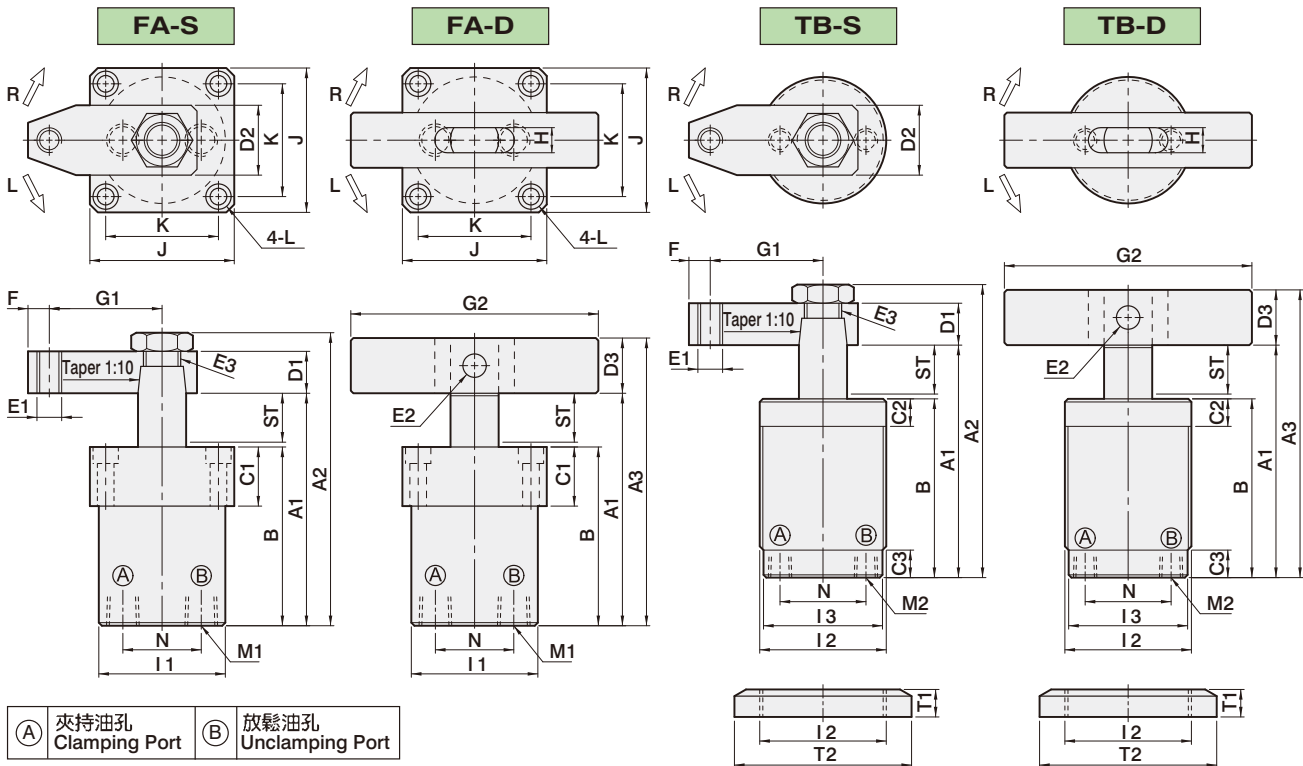

Dimensional table

UNIT:mm

MODEL	HSC-FA25 HSC-TB25	HSC-FA32 HSC-TB32	HSC-FA40 HSC-TB40	HSC-FA50 HSC-TB50	HSC-FA63
ST:Swing/Claming	22:9/13	26:11/15	26:11/15	30:13/17	30:13/17
A1	101	115	120	134	139
A2	(124)	(140)	(148)	(166)	(175)
A3	120	137.2	142.2	159.4	170.8
B	76	85	90	100	105
C1	22	25	25	30	30
C2 / C3	10 / 8	10 / 9	12 / 9	12 / 11	—
D1	15	17	18	20	23
D2	27	31	31	37	48
D3	$\square 19$	$\square 22.2$	$\square 22.2$	$\square 25.4$	$\square 31.8$
E1	M10x1.5	M10x1.5	M10x1.5	M12x1.75	M16x2.0
E2	$\phi 8$	$\phi 8$	$\phi 10$	$\phi 12$	$\phi 15$
E3	M14x1.5	M16x1.5	M18x1.5	M20x1.5	M26x1.5
F	10	10	10	12	15
G1	50	55	60	65	75
G2	140	160	160	180	200
H	9	10	10	12	15
I1	$\phi 45$	$\phi 50$	$\phi 58$	$\phi 68$	$\phi 81$
I2 / I3	M45x1.5 / $\phi 43$	M50x1.5 / $\phi 48$	M55x1.5 / $\phi 53$	M65x1.5 / $\phi 63$	—
J	53	57	69	75	90
K	40	44	52	58	70
L	$\phi 6.8\text{-}\phi 10.5 \times 6.5\text{D}$.	$\phi 6.8\text{-}\phi 10.5 \times 6.5\text{D}$.	$\phi 9\text{-}\phi 14 \times 9\text{D}$.	$\phi 9\text{-}\phi 14 \times 9\text{D}$.	$\phi 11\text{-}\phi 17 \times 11\text{D}$.
M1	PT1/4	PT1/4	PT1/4	PT1/4	PT1/4
M2	PT1/8	PT1/8	PT1/8	PT1/8	—
N	28	32	40	50	63
T1x2PCS	10	11	11	12	—
T2	$\phi 65$	$\phi 70$	$\phi 75$	$\phi 85$	—

网址: www.fdzc.net 联系人: 程家雄 手机: 13601809714

联系电话: 021-51872743

E-mail: chengff@sh163.net

HSC 油壓轉角缸 FAM 法蘭型油路板

Flange with manifold

Hydraulic Swing Clamp Cylinder FAM

• Bore: $\phi 25$ - $\phi 50$ mm • Pmax: 100kg/cm²

Single side swing clamp

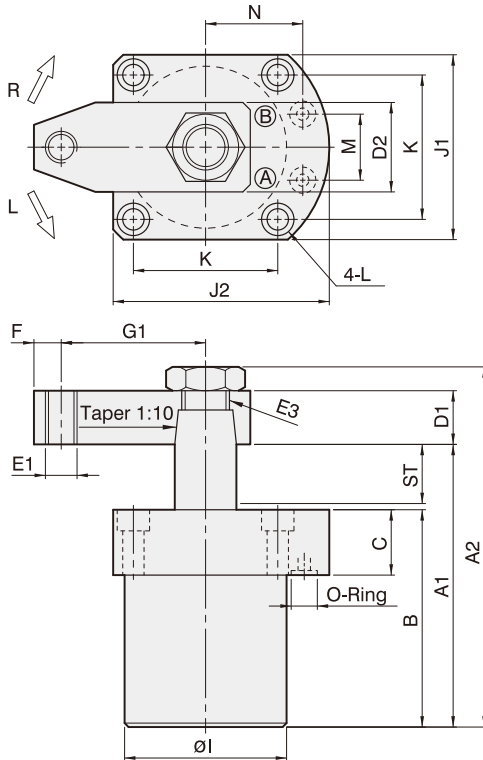

Double side swing clamp

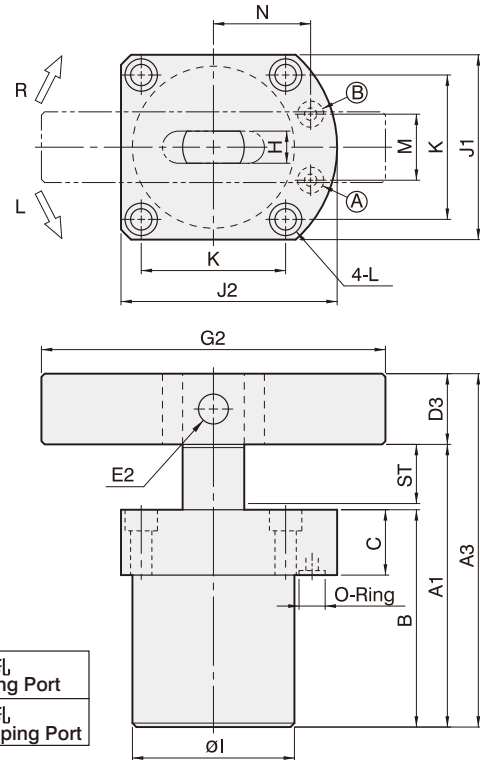

- (A) 夾持油孔
Clamping Port
- (B) 放鬆油孔
Unclamping Port

Dimensional table

UNIT:mm

ITEM \ MODEL	HSC-FAM25	HSC-FAM32	HSC-FAM40	HSC-FAM50
ST: Swing/Clamping	22:9/13	26:11/15	26:11/15	30:13/17
A1	101	115	120	134
A2	(124)	(140)	(148)	(166)
A3	120	137.2	142.2	159.4
B	76	85	90	100
C	22	25	25	30
D1	15	17	18	20
D2	27	31	31	37
D3	□ 19	□ 22.2	□ 22.2	□ 25.4
E1	M10x1.5	M10x1.5	M10x1.5	M12x1.75
E2	$\phi 8$	$\phi 8$	$\phi 10$	$\phi 12$
E3	M14x1.5	M16x1.5	M18x1.5	M20x1.5
F	10	10	10	12
G1	50	55	60	65
G2	140	160	160	180
H	9	10	10	12
$\phi 1$	$\phi 45$	$\phi 50$	$\phi 58$	$\phi 68$
J1	55	57	69	75
J2	64	65.5	79	87
K	42	44	52	58
L	$\phi 6.8$ - $\phi 10.5$ x6.5D.	$\phi 6.8$ - $\phi 10.5$ x6.5D.	$\phi 9$ - $\phi 14$ x9D.	$\phi 9$ - $\phi 14$ x9D.
M	20	22	26	30
N	28	29	34.5	39
O-Ring	P6	P6	P9	P9

网址: www.fdzc.net 联系人: 程家雄 手机: 13601809714

联系电话: 021-51872743

E-mail: chengff@sh163.net

HSC 油壓轉角缸 FCM法蘭型油路板附調速

Flange type manifold with flow control

EZ CLAMP

Hydraulic Swing Clamp Cylinder FCM

• Bore: $\phi 25$ - $\phi 50$ mm • Pmax: 100kg/cm²

Single side swing clamp

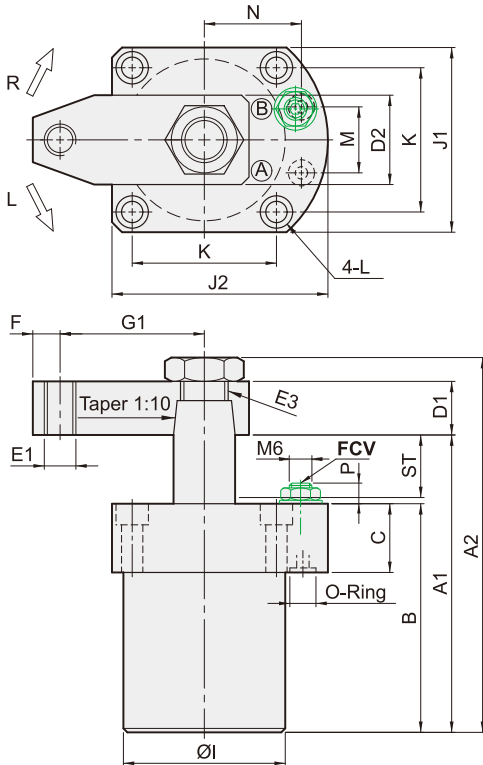

Double side swing clamp

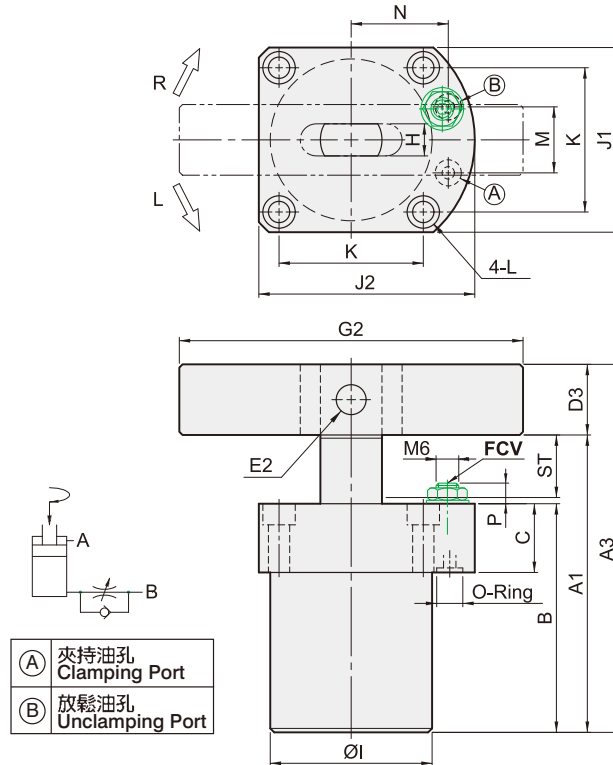

Dimensional table

UNIT:mm

ITEM \ MODEL	HSC-FCM25	HSC-FCM32	HSC-FCM40	HSC-FCM50	HSC-FCM63
ST:Swing/Clamping	22:9/13	26:11/15	26:11/15	30:13/17	30:13/17
A1	101	115	120	134	139
A2	(124)	(140)	(148)	(166)	(175)
A3	120	137.2	142.2	159.4	170.8
B	76	85	90	100	105
C	22	25	25	30	30
D1	15	17	18	20	23
D2	27	31	31	37	48
D3	□19	□22.2	□22.2	□25.4	□31.8
E1	M10x1.5	M10x1.5	M10x1.5	M12x1.75	M16x2.0
E2	$\phi 8$	$\phi 8$	$\phi 10$	$\phi 12$	$\phi 15$
E3	M14x1.5	M16x1.5	M18x1.5	M20x1.5	M26x1.5
F	10	10	10	12	15
G1	50	55	60	65	75
G2	140	160	160	180	200
H	9	10	10	12	15
ϕl	45	50	58	68	81
J1	55	57	69	75	90
J2	64	65.5	79	87	104
K	42	44	52	58	70
L	$\phi 6.8$ - $\phi 10.5$ x6.5D.	$\phi 6.8$ - $\phi 10.5$ x6.5D.	$\phi 9$ - $\phi 14$ x9D.	$\phi 9$ - $\phi 14$ x9D.	$\phi 11$ - $\phi 17$ x11D.
M	20	22	26	30	34
N	28	29	34.5	39	47
O-Ring	P6	P6	P9	P9	P9
P Min	7	4.5	4.5	4	4
P Max	9.9	7.8	7.8	7.3	7.3

网址: www.fdzc.net 联系人: 程家雄 手机: 13601809714

联系电话: 021-51872743 E-mail: chengff@sh163.net